

Item No.

High Performance, Fast Recovery, Energy-Saving...Half the Space, Half a Fryer

When you need one more basket for shrimp, fish or onion rings but don't have the space for a full size fryer, use the new Anets Half-Fryer. Attached to a full-size fryer, it provides a very cost-efficient way to expand your offerings. Available with a fully automatic basket lift and 15 minute timer (Model MX-7A).

STANDARD FEATURES

- Stainless steel frypot has a lifetime warranty
- Stainless steel front panel, trim and door
- Top quality tri-clad stainless steel frypot provides efficient uniform heat transfer
- Copper-flashed heat exchangers transfer heat directly into frypot for maximum efficiency
- Open vat design with sloped sides forces food particles to fall into the easily accessible cold zone
- Fully insulated cabinet keeps the kitchen cool
- Stainless steel basket hanger lifts off for easy cleaning
- Front 1-1/4" NPT drain
- Unit must be banked to a 14" fryer.



MX-7E shown banked with an MX-14E and optional casters

A N E T S
GoldenFRY™



ANETS

Anetsberger Brothers, Inc. ■ Foodservice Equipment That Turns Food Into Gold
180 North Anets Drive ■ Northbrook, Illinois 60062
1-800-837-2638 ■ Fax 847-272-1943 ■ www.anetsberger.com



SPECIFICATIONS

- Models
 - MX-7E, Basic
 - MX-7A, Fully automatic basket lift with 15 minute timer
- Certification
 - UL, NSF
- Gas Input
 - 55,000 BTU/hr.
- Gas Pressure
 - NG 3.5" WC, LP 10" WC
- Gas Connection
 - 3/4" NPT
- Electrical Requirements
 - MX-7E, 2 Amps
 - MX-7A, 3.5 Amps
- Thermostat
 - Electric snap action type
- Temperature Range
 - 200 to 375F (93-191C)
- Burners
 - Atmospheric pre-mix
- Hi-limit
 - Safety control turns off main gas supply at 435F (224C)
- Safety Pilot
 - 100% gas shut off valve
- Spark Ignitor
 - Piezo-electric
- Frypot
 - Tri-clad stainless steel
- Cabinet
 - Door, stainless steel
 - Sides, painted
 - Backsplash, stainless steel
- Shortening Capacity
 - 17-25 lbs

STANDARD ACCESSORIES

- 1 Nickel plated twin basket
- Rack type basket support
- Clean out rod
- 6" adjustable chrome plated legs
- Drain pipe extension
- Banked to a standard 14" fryer

OPTIONS AND ACCESSORIES

- Stainless steel cabinet side
- Built-in filter system, Filtronic II
- Casters
- Fryer cover
- Drain table
- Sediment tray

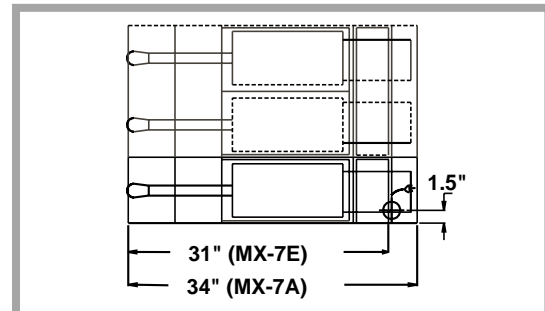

Top View

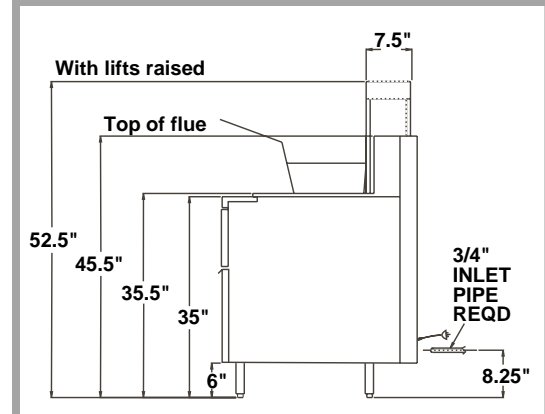

Side View

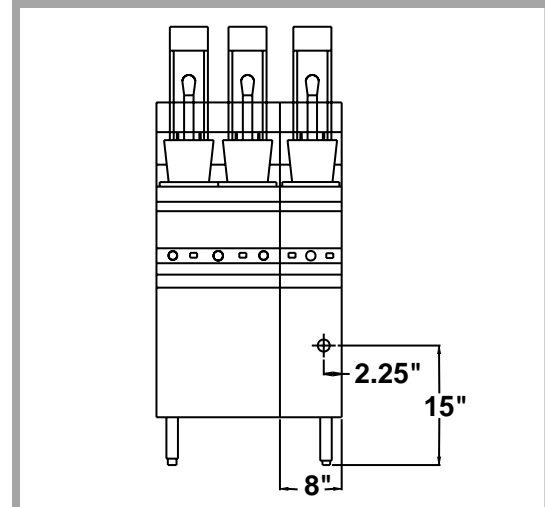

Front View

Specifications subject to change without notice.
 SS#110 8/01
 Printed in the U.S.A.