



BCX-14E and ZEPHAIRE-E PLUS

BCX Series Combi Stacked on a Full-Size Electric Convection Oven



Shown with optional casters

ZEPHAIRE E PLUS OPTIONS AND ACCESSORIES (AT ADDITIONAL CHARGE)

- 6" (152mm) casters
- Extra oven racks
- 480 VAC, 3 phase
- Extended warranty

Project _____

Item No. _____

Quantity _____

Requires Blodgett stacking kit SK-88FS.

ZEPHAIRE E PLUS SPECIFICATIONS

EXTERIOR CONSTRUCTION

- Full angle-iron frame
- Stainless steel front, top, and sides
- Dual pane thermal glass windows encased in stainless steel door frames
- Porcelain door handle with simultaneous door operation
- Triple-mounted pressure lock door design with turnbuckle assembly
- Removable front control panel
- Solid mineral fiber insulation at top, back, sides and bottom

INTERIOR CONSTRUCTION

- Double-sided porcelainized baking compartment liner (14 gauge)
- Aluminized blower wheel
- Five chrome-plated racks, eleven rack positions with a minimum of 1-5/8" (41mm) spacing

OPERATION

- Three tubular heaters
- Solid state thermostat with temperature control range of 200°F (93°C) to 500°F (260°C)
- Two speed fan motor
- 1/3 horsepower blower motor with automatic thermal overload protection
- Control area cooling fan
- Two 50 watt commercial bake oven lamps

CAPACITY

- Extra depth baking compartment - accepts five 18" x 26" standard full-size baking pans in left-to-right or front-to-back positions.

STANDARD FEATURES

- Solid state manual controls with separate dials for thermostat and timer
- 6" (152mm) adjustable stainless steel legs
- 60 minute electric timer with buzzer
- One year parts and labor warranty*
- Three year limited oven door warranty*

* For all international markets, contact your local distributor.

BCX-14E STACKED ON A ZEPHAIRE-E PLUS



BLODGETT OVEN COMPANY

www.blodgett.com

44 Lakeside Avenue, Burlington, VT 05401 • Toll Free: (800) 331-5842 • Phone: (802) 860-3700 • Fax: (802) 864-0183



BCX-14E and ZEPHAIRE-E PLUS

BCX Series Combi Stacked on a Full-Size Electric Convection Oven



Shown with optional casters

OPTIONS AND ACCESSORIES

(AT ADDITIONAL CHARGE)

- **Voltage options**
 - 480VAC, 3 phase
 - 415/240VAC, 3 phase
- MenuSelect control can hold multi-stage programming for up to 99 products, includes Cook & Hold and core probe cooking
- Additional 6-1/2" core temperature probe
- Additional stainless steel wire shelves
- Chicken roasting rack
- Single source water manifold
- Water pressure regulator
- Extended warranty

BCX-14E COMBI SPECIFICATIONS

EXTERIOR CONSTRUCTION

- Stainless steel top, front and sides
- Dual pane tempered viewing window with hinged inner glass for easy cleaning
- Door mounted condensate trough
- Top and bottom mount, easily adjustable door hinges
- Pivot out user interface panel for service access

INTERIOR CONSTRUCTION

- Fully welded stainless steel frame
- Fully insulated cooking chamber
- Fixed drain bottom center of cavity
- Easily removable stainless steel side rails
- Coved corner liner for ease of cleaning

OPERATION

- Standard control with function selection for steam, combi, hot air, and cool down
- Retherm band on control
- Steam on demand feature
- Thermostat control to 500F
- Multiple speed reversing fan for even bake
- Dual stage door latch to vent steam before fully opening door
- Cavity vent control provides ability to release steam at the turn of a switch
- Integral door switch
- Open vented system. Condenses steam and drains away by-products of the cooking process, eliminates flavor transfer
- Self contained, self-flushing steam generator separate from cooking compartment for instant steam recovery when switching modes
- Control prompts user to delime when steam generator requires delimiting

CAPACITY

- Fourteen 12" x 20" x 2-1/2" deep pans at 3-1/4" spacing
- Seven 18" x 26" deep pans at 3-1/4" spacing

STANDARD FEATURES

- Five (5) stainless steel wire shelves per section (capacity for 7)
- Hinged pressure panel for cleanability
- Four halogen lights for superior cavity illumination
- Retractable hose reel hidden behind door, no extraneous hoses
- Stacking kit and casters for double stack ovens
- Semi-auto delime system
- Delimiting bottle assembly
- Pressure spray bottle for oven cleaning
- 6-1/2" core temperature probe
- Start-up inspection service by factory authorized service agent
- One year parts and labor oven warranty*

* For all international markets, contact your local distributor.

BCX-14E STACKED ON A ZEPHAIRE-E PLUS



BLODGETT OVEN COMPANY

www.blodgett.com

44 Lakeside Avenue, Burlington, VT 05401 • Toll Free: (800) 331-584 • Phone: (802) 860-3700 • Fax: (802) 864-0183



BCX-14E STACKED ON A ZEPHAIRE-E PLUS

DIMENSIONS ARE IN INCHES (MM)

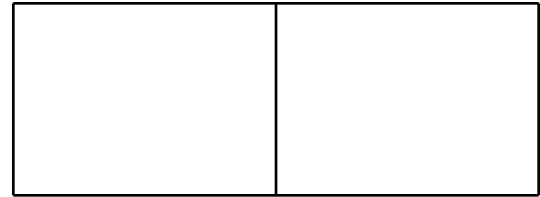
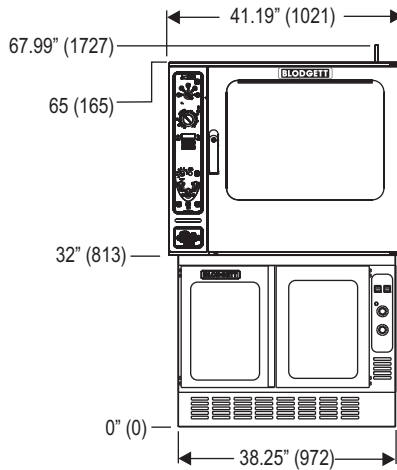
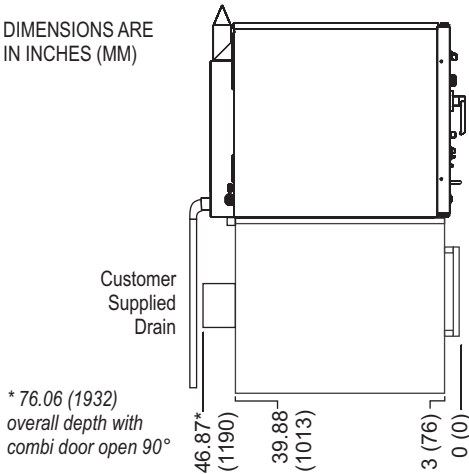

APPROVAL/STAMP

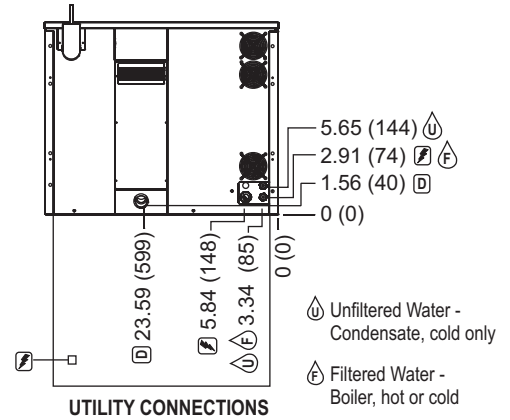

SHORT FORM SPECIFICATIONS

Provide Blodgett model BCX-14E electric combination-oven/steamer stacked on a model ZEPHAIRE E PLUS full-size electric convection oven.

BCX-14E Combi - Unit shall have the ability to cook with pressureless steam (212F), hot air, or combination of steam and hot air (with an operating range 140F to 500F), vario-steaming (operating range 140F to 212F), low temperature cooking and holding, rethermalizing, cool down mode and our Exclusive Steam on Demand steam injection system. Oven capacity to accept 7ea 18x26 bake pans or 14ea 12x20x2.5" full size steam table pans with 3-1/4" spacing. Front access service user interface control panel and service diagnosis system. Unit shall be constructed with a fully welded stainless steel frame. Cooking chamber shall be constructed with 304 series with bright-annealed stainless steel finish and coved corners. Integrated retractable wash down hose to include front water shut off valve. Oven cavity shall be open to the atmosphere with a thermostatically controlled quench box with a flow rate of less than 8 gallons per hour (total water consumption not to exceed 15 gallons per hour). Unit shall include a four speed, bi-directional fan with vent switch to control humidity in the cooking chamber. Dual pane thermal glass window with 180 degree door swing, two-step safety door-latch with adjustable door hinges, door mounted drip pan. Unit to include a detachable 6-1/2" core temperature probe and four halogen lights. Supply with exclusive time to delime indicator with adjustable settings of 30, 60 or 90 hours of run time, semi-automatic deliming system. Where applicable, quantities in this spec are doubled for stacked units. A start-up inspection service will be performed by our factory-authorized agent at no cost to the operator. One-year parts and labor warranty, standard.

Zephaire E Plus - Shall have porcelainized steel liner and shall accept five 18" x 26" standard full-size bake pans in left-to-right or front-to-back positions. Doors shall have dual pane thermal glass windows with single porcelain handle and simultaneous operation. Unit shall be electrically heated with three tubular heaters. Air in baking chamber distributed by single inlet blower wheel powered by a two-speed, 1/3 HP motor with thermal overload protection. Each chamber shall be fitted with five chrome-plated removable racks. Control panel shall be recessed with Cook/Cool Down mode selector, solid state manual infinite thermostat (200 - 500°F), and 60-minute timer.

Provide options and accessories as indicated.

DIMENSIONS:

Product Clearance: 6" (rear), 1" (right side), 4" (left side) from combustible and non-combustible construction. 12" on left side if not on casters.

Additional Height:

6" adjustable legs 6-7/8" - 8" (174.6-203.2mm)

MINIMUM ENTRY CLEARANCE:

	BCX-14E	Zephaire E Plus
Uncrated	33" (838mm)	32-1/16" (814mm)
Crated	42" (1066.8mm)	37-1/2" (953mm)

POWER SUPPLY - ZEPHAIRE E PLUS

208 VAC	60 Hz.	1 phase	11KW	51/0/51 Amperes,
208 VAC	60 Hz.	3 phase	11KW	31/29/29 Amperes,
220/240 VAC	60 Hz.	1 phase	11KW	44/0/44 Amperes,
220/240 VAC	60 Hz.	3 phase	11KW	26/24/24 Amperes,
440 VAC	60 Hz.	3 phase	11KW	15/14/14 Amperes,
480 VAC	60 Hz.	3 phase	11KW	14/13/13 Amperes,

1/3 HP, 2 speed motor, 1140 & 1725 rpm (60 Hz)

(50 Hz. ovens for 400/230, 380Y/220 VAC or 415Y/240 VAC (4 wire) 3 phase)

This oven contains a mercury relay. DO NOT put mercury relay in trash. Relay must be recycled or disposed of as hazardous waste.

POWER SUPPLY - BCX-14E:

208VAC	19.0 kW	3 phase (53 amp)
240VAC	19.0 kW	3 phase (46 amp)
480VAC	19.0 kW	3 phase (23 amp)
415VAC	19.0 kW	3 phase (26.5 amp) 5 wire

WATER SUPPLY (BCX-14E only):

TDS: < 100 ppm Hardness: 80-120 ppm pH: 7.0 - 8.0
 Chlorides: < 30 ppm Chlorine: 0 ppm 30(min)-50(max) PSI
 140°F (60°C) avg. drain temp.
 2" drain connection 3/4" garden hose cold water
 Appliance is to be installed with backflow protection in accordance with Federal, State or Local codes.

SHIPPING INFORMATION:

Approximate Weight:

BCX-14E	615 lbs. (279 kg)
Zephaire E Plus	545 lbs. (247 kg)

Crate sizes:

BCX-14E	44.5" H x 42" W x 54.5" D (1130 x 1067 x 1384mm)
Zephaire E Plus	37-1/2" (952mm) x 43-1/2" (1105mm) x 52" (1321mm)

NOTE: The company reserves the right to make substitutions of components without prior notice

BLODGETT OVEN COMPANY

www.blodgett.com

44 Lakeside Avenue, Burlington, VT 05401 • Toll Free: (800) 331-5842 • Phone: (802) 860-3700 • Fax: (802) 864-0183