



CTB/CTBR

Project _____

Item No. _____

Quantity _____

MODEL CTB/CTBR Half-Size Electric Convection Oven



Standard depth baking compartment - accepts 13" x 18" standard half-size baking pans in front-to-back-position. CTBR model follows same specifications as CTB, only with door opening on the right side and controls on left side.

All data is shown per oven section, unless otherwise indicated.

Refer to operator manual specification chart for listed model names.

EXTERIOR CONSTRUCTION

- Full angle-iron frame
- Stainless steel front, top, sides and back
- Dual pane thermal glass window encased in stainless steel door frame
- Single chrome plated door handle
- Tilt-down modular front control panel
- Solid mineral fiber insulation at top, back, sides and bottom

INTERIOR CONSTRUCTION

- Double-sided porcelainized baking compartment liner (14 gauge)
- Five chrome-plated racks, nine rack positions with a minimum of 1-5/8" (41mm) spacing

OPERATION

- Two tubular heaters (5kW)
- Solid state thermostat with temperature control range of 200°F (93°C) to 500°F (260°C)
- Two speed fan motor
- 1/4 horsepower blower motor with automatic thermal overload protection
- One control area cooling fan

STANDARD FEATURES

- Solid state manual with separate dials to control thermostat and time**
- Two year oven parts and one year labor warranty*
- Five year oven door warranty*

* For all international markets, contact your local distributor.

** For control panels other than standard consult your local international distributor for CE approvals.

OPTIONS AND ACCESSORIES

(AT ADDITIONAL CHARGE)

- **Legs/casters:**
 - 4" (102mm) black legs (not for use with stands)
 - 6" (152mm) casters
- **Stands:**
 - 5-3/4" (146mm) stainless steel stand
 - 7" (178mm) stainless steel stand
 - 16" (406mm) stainless steel stand
 - 19" (438mm) stainless steel stand with shelf
 - 24" (610mm) stainless steel stand with shelf
 - 33" (838mm) stainless steel stand with shelf
- Solid state digital with cook and hold, and Pulse Plus® with digital display
- Vent riser: stainless steel
- Cord set with receptacle
- 7.5 Kw elements
- Extra oven racks
- Oven Liner: Stainless steel

OPTIONS AND ACCESSORIES

(AT NO CHARGE)

- Door Design: Solid stainless steel
- Right hand hinged door



BLODGETT OVEN COMPANY

www.blodgett.com

44 Lakeside Avenue, Burlington, VT 05401

Toll Free: (800) 331-5842 • Phone: (802) 860-3700 • Fax: (802) 864-0183



MODEL CTB/CTBR

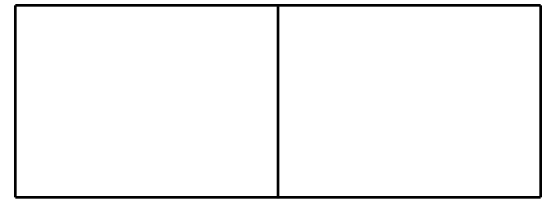

APPROVAL/STAMP

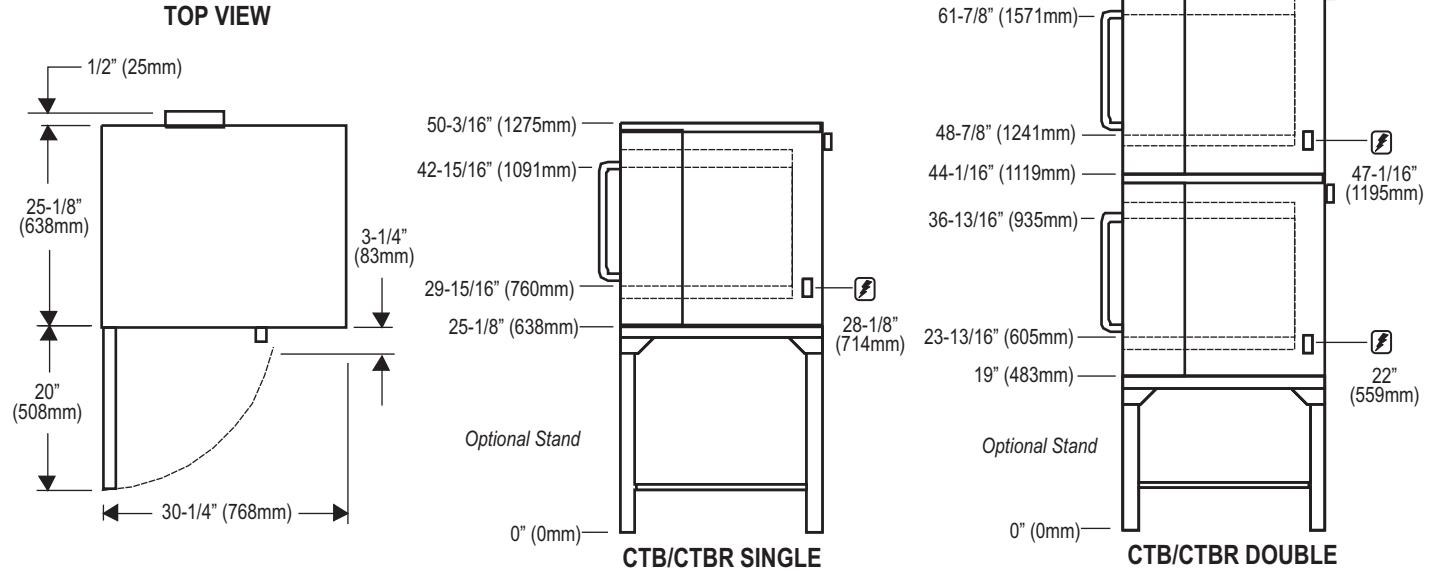

SHORT FORM SPECIFICATIONS

Provide Blodgett half-size convection oven model CTB/CTBR (single, double) compartment. Each compartment shall have (porcelainized/stainless) steel liner and shall accept five 13" x 18", standard half-size bake pans. Doors shall be (dual pane thermal glass/window/solid stainless steel door) with single chrome plated door handle. Stainless steel front, top, sides and legs. Unit shall be electrically heated with two or three tabular heaters dependent on wattage (5 or 7.5 kW) selection. Air in baking chamber distributed by blower wheel powered by two-speed, 1/4 horsepower motor with thermal overload protection. Each chamber shall be fitted with five chrome plated removable racks, and have nine rack positions. Control panel shall be recessed with Cook/Cool Down mode selector, solid state (manual/digital) infinite thermostat (200°-500°F), and 60-minute timer. Provide options and accessories as indicated.

DIMENSIONS:

Floor space 30-1/4" (768mm) W x 25-1/8" (638mm) D
Product clearance 0" from combustible and non-combustible construction.
Interior 15-1/4" (387mm) W x 20" (508mm) H x 21" (533mm) D

MAXIMUM INPUT:

CTB/CTBR single 5.6KW (8.0 KW increase option available)
 CTB/CTBR double 11.2KW (16 KW increase option available)

MINIMUM ENTRY CLEARANCE:

Uncrated 25-1/16" (636mm)
 Crated 30-1/4" (775mm)

SHIPPING INFORMATION:

Approx. Weight:

Single 295 lbs. (134 kg)
 Double 595 lbs. (270 kg)

Crate size:

36" (914mm) L x 32" (813mm) W x 35" (889mm) H

NOTE: The company reserves the right to make substitutions of components without prior notice

POWER SUPPLY:

V.A.C.	Hz	Phase	K.W.H.	Amperes (L1-L2-L3)
STANDARD				
208	60	1	5.6	27/0/27
208	60	3	5.6	24/12/15
220-240	60	1	5.6	24/0/24
220-240	60	3	5.6	21/11/14
INCREASED OUTPUT				
208	60	1	8	35/0/35
208	60	3	8	22/20/21
220-240	60	1	8	32/0/32
220-240	60	3	8	20/18/19
EXPORT				
208	50	1	5.6	27/0/27
220-240	50	1	5.6	24/0/24
220-240	50	1	8	35/0/35
220/380	50	3 WYE	5.6	10/8/8
220/380	50	3 WYE	8	14/12/12
240/415	50	3 WYE	5.6	11/0/9
240/415	50	3 WYE	8	13/11/11
230/400	50	3 WYE	5.6	11/0/10
230/400	50	3 WYE	8	13/11/11

INCREASED OUTPUT

EXPORT

BLODGETT OVEN COMPANY

www.blodgett.com

44 Lakeside Avenue, Burlington, VT 05401

Toll Free: (800) 331-5842 • Phone: (802) 860-3700 • Fax: (802) 864-0183

1/4 H.P., 2 speed motor, 1140 and 1725 RPM (60Hz.)

1/4 H.P., 2 speed motor, 1425 and 950 (50Hz.)