



ZEPHAIRE-E

MODEL ZEPHAIRE-E Full-size Electric Convection Oven



Project _____

Item No. _____

Quantity _____

Refer to operator manual specification chart for listed model name.

Extra depth baking compartment- accepts five 18" x 26" standard full-size baking pans in left-to-right or front-to-back positions.

All data is shown per oven section, unless otherwise indicated.

Refer to operator manual specification chart for listed model name.

EXTERIOR CONSTRUCTION

- Full angle-iron frame
- Stainless steel front, top, and sides
- Solid dependent stainless steel doors
- Porcelain door handle with simultaneous door operation
- Triple-mounted pressure lock door design with turnbuckle assembly
- Removable front control panel
- Solid mineral fiber insulation at top, back, sides and bottom

INTERIOR CONSTRUCTION

- Double-sided porcelainized baking compartment liner (14 gauge)
- Aluminized blower wheel
- Five chrome-plated racks, eleven rack positions with a minimum of 1-5/8" (41mm) spacing

OPERATION

- Three tubular heaters
- Solid state thermostat with temperature control range of 200°F (93°C) to 500°F (260°C)
- Single speed fan motor
- 1/3 horsepower blower motor with automatic thermal overload protection
- Control area cooling fan

STANDARD FEATURES

- Solid state manual controls with separate dials for thermostat and timer
- 25" (635mm) adjustable stainless steel legs (for single units)
- 6" (152mm) adjustable stainless steel legs (for double sections)
- 60 minute electric timer with buzzer
- One year parts and labor warranty*
- Three year limited oven door warranty*

* For all international markets, contact your local distributor.

OPTIONS AND ACCESSORIES

(AT ADDITIONAL CHARGE)

- **Legs/casters/stand:**
 - 6" (152mm) seismic legs
 - 6" (152mm) casters
 - 4" (102mm) low profile casters (double only)
 - 25" (635mm) stainless steel open stand with rack guides
- Solid stainless back panel
- Extra oven racks
- Plus package (glass doors, interior lights, and a two speed motor)
- Vent connector
- 480 VAC, 3 phase
- Extended warranty



BLODGETT OVEN COMPANY

www.blodgett.com

44 Lakeside Avenue, Burlington, VT 05401

Toll Free: (800) 331-5842 • Phone: (802) 860-3700 • Fax: (802) 864-0183



MODEL ZEPHAIRE-E

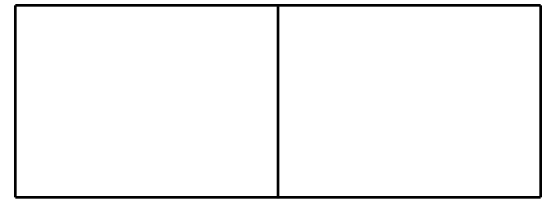

APPROVAL/STAMP

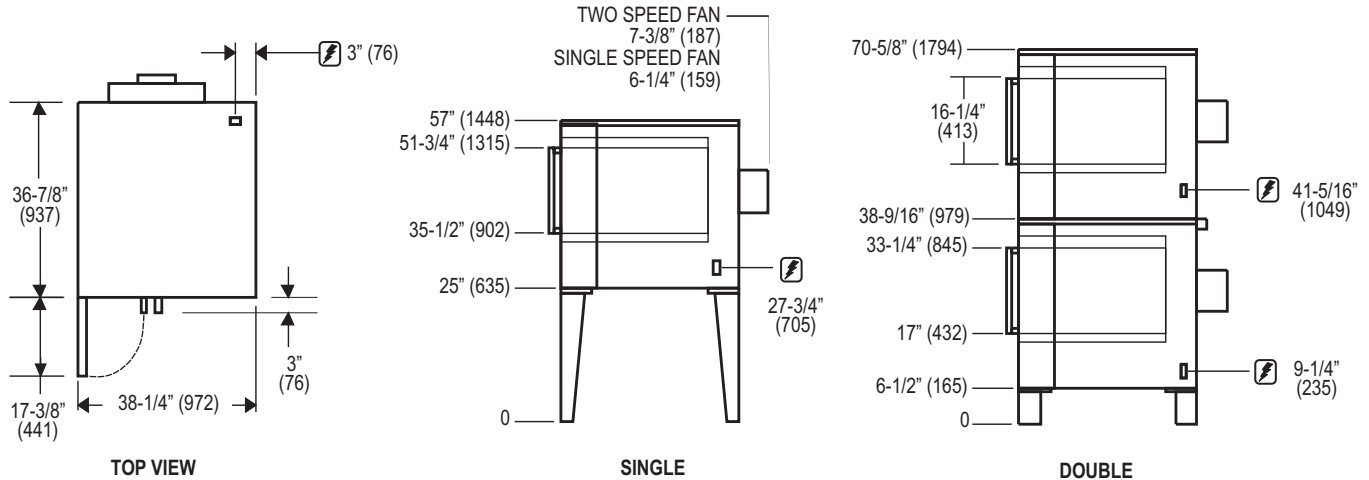

SHORT FORM SPECIFICATIONS

Provide Blodgett full-size convection oven model ZEPHAIRE-E, (single/double) compartment. Each compartment shall have porcelainized steel liner and shall accept five 18" x 26" standard full-size bake pans in left-to-right or front-to-back positions. Doors shall be solid stainless steel with porcelain door handle and simultaneous door operation. Unit shall be electrically heated with three tubular heaters. Air in baking chamber distributed by single inlet blower wheel powered by a single-speed, 1/3 HP motor with thermal overload protection. Each chamber shall be fitted with five chrome-plated removable racks. Control panel shall be recessed with Cook/Cool Down mode selector, solid state manual infinite thermostat (200 - 500°F), and 60-minute timer. Provide options and accessories as indicated.

DIMENSIONS:

Floor space: 38-1/4" (972mm) W x 36-7/8" (936mm) L
Product clearance: 1/2" from combustible and non-combustible construction.
Interior: 29" (737mm) W x 20" (508mm) H x 28-1/4" (718mm) D
If oven is on casters add to all height dimensions:
 Single 4-1/2" (114mm)
 Double 2-1/4" (57mm)

MAXIMUM INPUT:

Single 11KW
 Double 22Kw (11KW each section)

POWER SUPPLY:

208 VAC 60 Hz. 1 phase 11KW 51/0/51 Amperes,
 208 VAC 60 Hz. 3 phase 11KW 31/29/29 Amperes,
 220/240 VAC 60 Hz. 1 phase 11KW 44/0/44 Amperes,
 220/240 VAC 60 Hz. 3 phase 11KW 26/24/24 Amperes,
 440 VAC 60 Hz. 3 phase 11KW 15/14/14 Amperes,
 480 VAC 60 Hz. 3 phase 11KW 14/13/13 Amperes,
 1/3 HP, 1 speed motor, 1725 rpm (60 Hz)
 (50 Hz. ovens for 400/230, 380Y/220 VAC or 415Y/240 VAC (4 wire) 3 phase are available)

MINIMUM ENTRY CLEARANCE:

Uncrated 32-1/16" (814mm)
 Crated 37-1/2" (953mm)

SHIPPING INFORMATION:

Approx. Weight:
 Single: 545 lbs. (247 kg)
 Double: 1060 lbs. (481 kg)
Crate sizes:
 37-1/2" (952mm) x 43-1/2" (1105mm) x 51-3/4" (1315mm)

NOTE: The company reserves the right to make substitutions of components without prior notice

BLODGETT OVEN COMPANY

www.blodgett.com

44 Lakeside Avenue, Burlington, VT 05401 Toll Free: (800) 331-5842 • Phone: (802) 860-3700 • Fax: (802) 864-0183