



Your Solutions Partner

Specifications

F.O.B Sedalia, Missouri 65301



HB2CS

(Shown w/optional trayslides and drawer)

OPTIONS:

- Stainless steel drawer
- Internal locking device
- Cylinder lock and keys on drawer
- 1-color laminate on body/second color laminate on tray slide
- Laminate finish other than standard eight (8) finishes
- Kickplates (stainless) (painted) (laminate to match body)
- Trayslides
- Legs in lieu of casters

Approval Stamp(s):

PRODUCT INFORMATION:

PROJECT: _____

ITEM: _____

QUANTITY: _____

MODEL:

Heritage® Buffet Cashier Unit

- HB2CS** 36"H x 26-1/2"W x 24-1/2" L

TOP:

- 16 gauge, 300 Series stainless steel
- Flanged down 2" on all four sides

BODY:

- Heavy gauge paint grip steel
- Body panels supported by 14 gauge steel frame
- Laminate patterns:

<input type="checkbox"/> Beige Grafix - HB-01	<input type="checkbox"/> Northern Oak - HB-06
<input type="checkbox"/> Ebony Star - HB-03	<input type="checkbox"/> Ubatuba Granite - HB-13
<input type="checkbox"/> Oxide - HB-04	<input type="checkbox"/> Amber Maple - HB-12
<input type="checkbox"/> Fallen Leaves - HB-07	
<input type="checkbox"/> Acajou Mahogany - HB-11	
- Stainless steel trim strips on corners
- Flanged and channeled edges for strength
- Welded together with reinforcements
- Bottom shelf - heavy gauge paint grip steel, powder coat painted black, brown or copper
- Open on end for knee room
- Mounted on NSF listed 5" diameter swivel casters, two with locks, all non-marking polyurethane tires

DUKE MANUFACTURING CO.
 2305 N. Broadway
 St. Louis, MO 63102

800.735.3853 Toll Free
314.231.5074 Fax
www.dukemfg.com

HERITAGE®

HERITAGE® BUFFET CASHIER UNIT

□ HB2CS 36" H x 26-1/2"W x 24-1/2"L

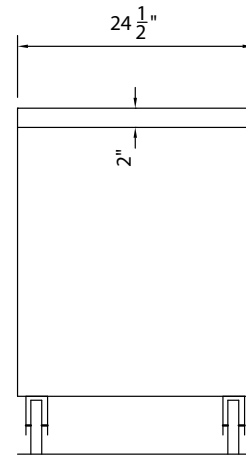
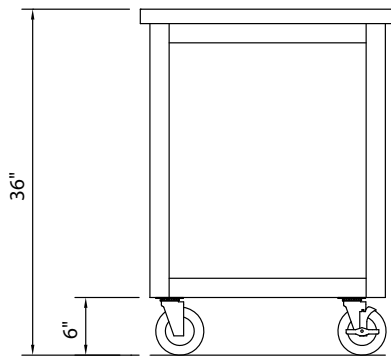
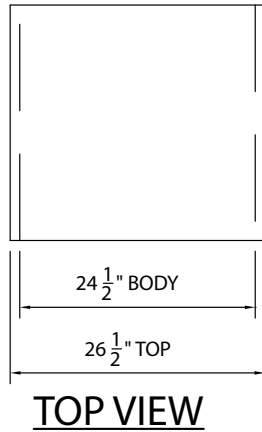

DIMENSIONS:

FREIGHT CLASS: 150

Model	Length		Width		Heights		Cube ft. Crated	Weight	
	in	cm	in	cm	in	cm		lbs	kg
HB2CS	26-1/2"	67.3	24-1/2"	62.2	36	91.4	21.1	250	113.6

OPTIONAL DRAWER DIMENSIONS:

Model	Depth (liner)		Width (liner)		Heights (liner)		Drawer Face Width		Drawer Face Height	
	in	cm	in	cm	in	cm	in	cm.	in	cm.
HB2CS	20	50.8	18-7/8"	48.1	3-1/2	8.8	19-3/4"	50.2	4-1/8	10.5

DUKE MANUFACTURING CO.

2305 N. Broadway
St. Louis, MO 63102

800.735.3853 Toll Free
314.231.1130 In Missouri
314.231.5074 Fax
www.dukemfg.com

