



CGB SERIES

Curved Glass Bakery Merchandisers

MODELS

- CGB-50
- CGB-59
- CGB-77

CGB-50

Front glass tilts out for easy cleaning and loading.

FEATURES

CLASSIFIED TO NSF STANDARDS FOR FOOD ZONE REQUIREMENTS

Benefits of this classification:

- Allows the storing of food in open containers, pans and platters
- Reduced packaging costs
- Quicker, more convenient service to customers

CONSTRUCTION

- 18 gauge painted steel base
- Stainless steel on top and sides
- Three adjustable white wire shelves
- Tempered thermopane tilt-out front glass
- Tempered thermopane glass ends

- Fluorescent top light and shelf light with T-8 bulbs
- Removable shelf lights, shelf supports and shelves
- Thermometer
- Black trim
- Removable white display deck
- Light switch
- Equipped with leveling legs to correct for unlevel flooring situations

DOORS

- Removable sliding rear doors with thermopane glass

REFRIGERATION

- Self-contained, hermetic condensing unit
- Rear air intake and discharge
- Refrigerant: R-134a
- Adjustable temperature control
- Condensate evaporator
- Off cycle defrost

- No minimum clearance required on cabinet sides but front, back and top must be left open for customer and operator access
- Temperature range: 38° to 40°F (3° to 4°C)

WARRANTY

- Standard limited four year extended compressor and one year limited parts and labor

OPTIONS

- Reflective end glass
- Reflective doors



CGB SERIES CURVED GLASS BAKERY MERCHANDISERS

TECHNICAL SPECIFICATIONS

MODEL	DIMENSIONS (in.)			DIMENSIONS (mm)			VOLTS	AMPS	UNIT H.P.	NO. OF SHELVES	STANDARD SHELF SIZE (in inches)	DISPLAY AREA CU. FT.	SHIP CU. FT.	SHIP WT. (LB/KG)
	L	D	H	L	D	H								
CGB-50	50 ¹ / ₈	35	48 ⁷ / ₁₆	1273	889	1230	115	10.5	1/2	3	21 ³ / ₈ x 46 ⁵ / ₈ bottom & middle, 15 ³ / ₄ x 46 ⁵ / ₈ top	20.8	85.0	640/291
CGB-59	59 ¹ / ₈	35	48 ⁷ / ₁₆	1502	889	1230	115	11.6	1/2	3	21 ³ / ₈ x 53 ⁵ / ₈ bottom & middle, 15 ³ / ₄ x 53 ⁵ / ₈ top	24.5	95.0	765/348
CGB-77	77 ¹ / ₈	35	48 ⁷ / ₁₆	1959	889	1230	115	14.2	3/4	6	21 ³ / ₈ x 35 ³ / ₄ bottom & middle (2 shelves), 15 ³ / ₄ x 35 ³ / ₄ top (2 shelves)	32.0	122.5	930/423

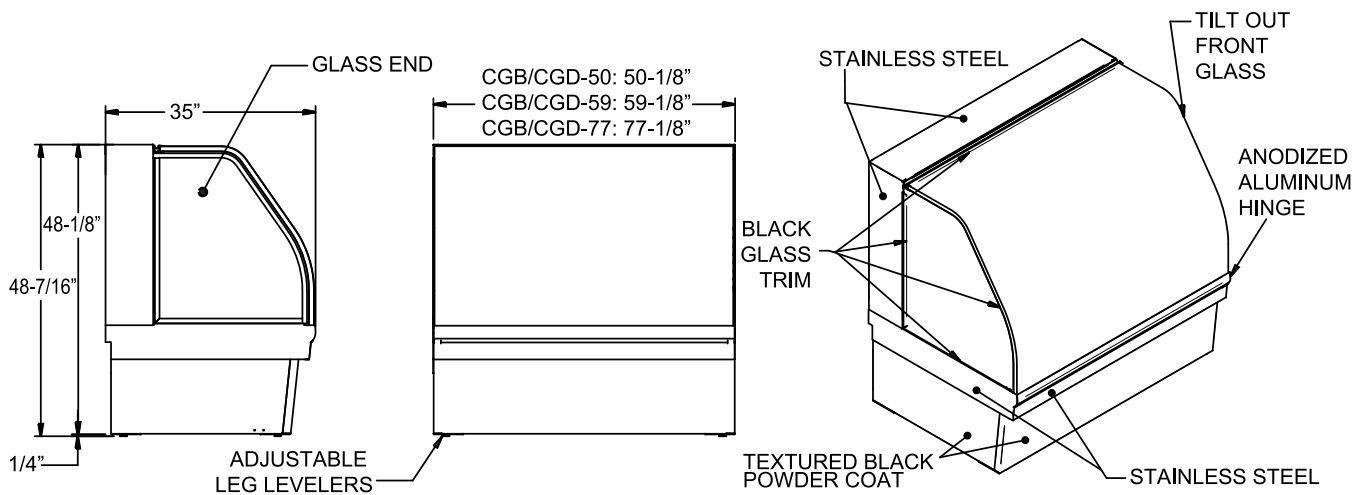

LISTINGS



HOOKUP

CGB-50 & CGB-59: Via plug in, 9 foot long flexible three wire 12AWG cord with molded plug.

CGB-77: Via plug in, 8 foot long flexible three wire 12AWG cord with molded plug.

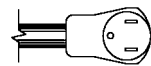

NEMA 5-15P
(CGB-50 & CGB-59)

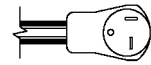

NEMA 5-20P
(CGB-77)

BID SPECIFICATIONS

Item no. CGB _____
Provide _____ () Curved Glass Bakery Merchandiser(s), Master-Bilt model no. CGB-_____.

Merchandiser to feature painted steel base with stainless steel top and sides. The front tempered thermopane glass will tilt out. Cabinet ends will also be constructed of thermopane glass. Glass front and ends will feature black trim.

Interior lighting provided by fluorescent

top and shelf lights with T8 bulbs. Three adjustable white wire shelves will also be standard. Shelf lights, shelf supports and shelves will be removable.

Rear sliding doors will be removable and will feature thermopane glass.

Other standard features will include a removable interior white display deck, thermometer, independent light switch, condensate evaporator and leveling legs.

The refrigeration system will be

self-contained and feature a hermetic condensing unit. The refrigerant will be R-134a. The temperature range will be 38° to 40°F (3° to 4°C).

Merchandiser to have standard limited four year extended compressor warranty and one year limited parts and labor warranty.

Merchandiser to be UL and C-UL listed and UL-EPH classified. Merchandiser also classified to NSF standards for food zone requirements.

NOTE: Cabinet designed for optimum performance in air-conditioned area at 75°F ambient and 55% relative humidity. All specifications subject to change without notice.



908 Highway 15 North • New Albany, MS 38652

PHONE: 800-647-1284 or 662-534-9061 • FAX: 800-232-3966 or 662-534-6049 • www.master-bilt.com

