

DD-LCG SERIES

Low Curved Glass Deluxe Ice Cream Dipping/Display Merchandisers

- MODELS**
- DD-46LCG
 - DD-66LCG
 - DD-88LCG

FEATURES

STANDARD ELECTRONIC CONTROL

- Decreases service time and calls
- Eliminates room thermostat

- CONSTRUCTION**
- Attractive, contemporary design
 - Equipped with leveling legs to correct for unlevel flooring situations
 - Rear air intake and discharge eliminates front grille and allows full front of cabinet for graphics
 - Independent on/off compressor and light switch
 - Stainless steel top and attached superstructure
 - Tempered plate glass viewing window
 - Drain with garden hose connector for ease of cleaning
 - Brilliant interior LED lighting
 - Stainless steel serving deck

- Heavy-duty epoxy-coated wire can support racks
- 9 ft. long cord with molded plug
- 2 1/4" foamed-in-place "zero ODP" urethane insulation

- FINISH**
- White painted steel exterior
 - 24 gauge white painted galvanized steel interior and back

- LIDS**
- Hinged, high-tensile, transparent acrylic dipping compartment lids with full length handle

- REFRIGERATION**
- Cold wall evaporator
 - Low maintenance bare tube condenser coil
 - Refrigerant:
 - DD-46LCGR-134a
 - DD-66LCG,
 - DD-88LCG..... R-404A
 - No minimum clearance required on cabinet sides but front, back and top must be left open for customer and operator access

- Temperature range: 5° to -5°F (-15° to -21°C)
- R-factor (insulation efficiency rating): 19.40

- WARRANTY**
- Standard limited three year extended compressor and two year limited parts and labor

OPTIONS

- Rear service doors (factory installed)
- Custom colors
- Removable can holders with white overnight can covers
- Dipper well
- Removable frost shields
- Leg kit
- Casters
- Lid locking kit (less locks)
- Ice cream pan rack assembly (pans not included)



DD-LCG SERIES

LOW CURVED GLASS DELUXE ICE CREAM DIPPING/DISPLAY MERCHANDISERS

TECHNICAL SPECIFICATIONS

MODEL	DIMENSIONS (in.)			DIMENSIONS (mm)			VOLTS	AMPS	UNIT H.P.	CAN CAP.* DISPLAY/STORAGE	CAP. CU. FT.†	SHIP CU. FT.	SHIP WT. LB/KG
	L	D	H	L	D	H							
DD-46LCG	47 ³ / ₄	27 ³ / ₄	50	1213	705	1270	115	7.5	1/2	8/4	9.6	54.0	370/168
DD-66LCG	69 ¹ / ₄	27 ³ / ₄	50	1759	705	1270	115	9.7	1/2	12/8	16.0	76.0	495/225
DD-88LCG	90 ³ / ₄	27 ³ / ₄	50	2305	705	1270	115	11.5	3/4	16/12	22.5	97.0	600/273

*Capacities in 9¹/₂" diameter, 3 gallon cans. †Measured to the load line level.

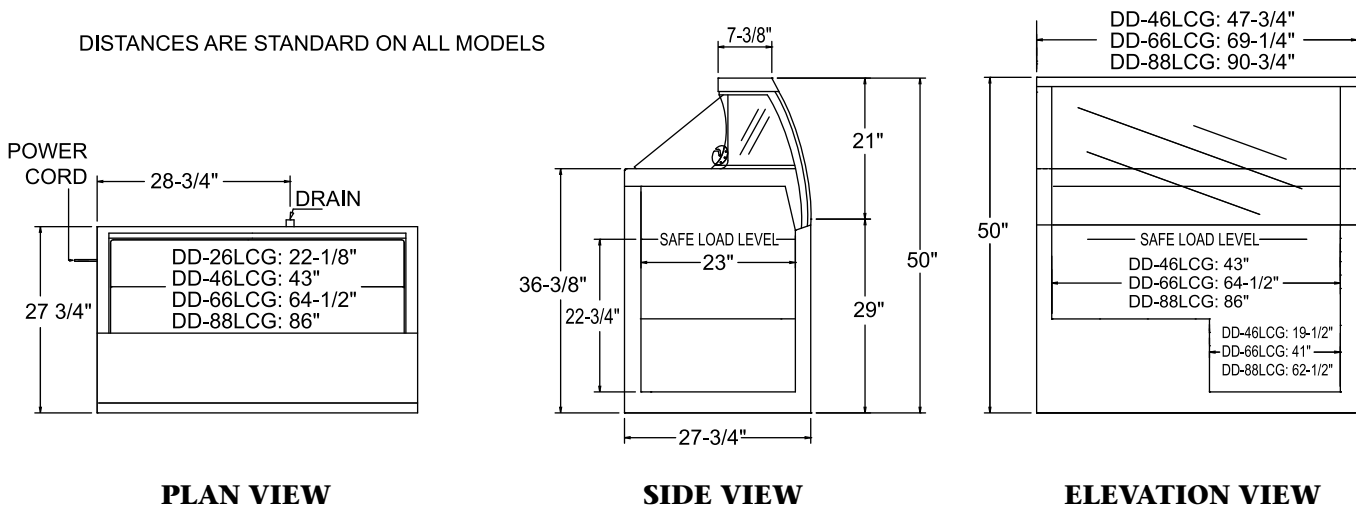

LISTINGS



HOOKUP

Via plug in, 9 foot long, flexible 3 wire 14/3 cord with molded plug. Drain hookup has standard garden hose connection.



BID SPECIFICATIONS

Item no. DD-_____
Provide _____ () Deluxe Ice Cream Dipping/Display Merchandiser(s), Master-Bilt model no. DD-_____.

Cabinet to have independent on/off compressor and light switch and will be equipped with an electronically controlled monitoring system. Cabinet to be provided with drain connection, stainless steel top

and superstructure, tempered plated glass viewing window and interior LED lighting. Cabinet is to have rear air intake and discharge. Standard leveling legs provided to correct for unlevel flooring situations.

Cabinet will be provided with 9 foot cord and molded plug.

DD-46LCG will use R-134a refrigerant while DD-66LCG and DD-88LCG will use

R-404A refrigerant. The temperature range will be 5° to -5°F (-15° to -21°C). All models to be supplied with a refrigeration system containing low maintenance bare tube condenser coil.

Cabinet to have standard limited three year extended compressor warranty and two year limited parts and labor warranty. Cabinet to be UL, C-UL and NSF listed.

NOTE: Cabinet designed for optimum performance in air-conditioned area at 75°F ambient and 55% relative humidity. All specifications subject to change without notice.



908 Highway 15 North • New Albany, MS 38652
PHONE: 800-647-1284 or 662-534-9061 • FAX: 800-232-3966 or 662-534-6049 • www.master-bilt.com

