

GT-60

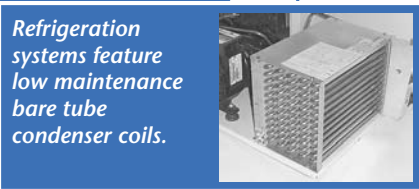

Refrigeration systems feature low maintenance bare tube condenser coils.

## GT SERIES

### Low Temp Horizontal Display Merchandisers

#### MODELS

- GT-30
- GT-40
- GT-50
- GT-60
- GT-80

## FEATURES

#### CONSTRUCTION

- 24 gauge painted steel interior and exterior
- Flat, 18" laminated white formica counter top
- Mirrored finish stainless steel light shield
- Anodized aluminum trim with black vinyl bumpers
- Protective front bumper
- Automatic condensate evaporator
- Equipped with high output T8HO lamps and electronic ballasts for greater energy efficiency
- Independent on/off light switch
- Front air discharge and intake
- Easily convertible to rear air discharge
- Independent on/off power switch
- 2" Foamed-in-place "zero ODP" urethane insulation

#### FINISH

- Sparkling white polyester enamel interior and exterior

#### LIDS

- Heat reflective lids with tempered glass
- Self-closing with hold-open feature for stocking

#### REFRIGERATION

- Self-contained, slide-out hermetic condensing unit
- Cold wall and gravity coil evaporator
- Refrigerant: R-404A
- With front air discharge and intake, cabinet back may be placed against a wall
- Temperature range: 0° to -20°F (-18° to -29°C)
- R-factor (insulation efficiency rating): 17.24

#### WARRANTY

- Standard limited four year extended compressor and one year limited parts and labor

## OPTIONS

- Custom colors
- Baskets
- Load level shelves
- Lighted two-shelf superstructure
- Lid locking kits (less locks)
- Sack rack
- Casters



# GT SERIES

## LOW TEMP HORIZONTAL DISPLAY MERCHANDISERS

### TECHNICAL SPECIFICATIONS

MODEL	DIMENSIONS (in.)			DIMENSIONS (mm)			VOLTS	AMPS	UNIT H.P.	NO. OF LIDS	BASKET CAPACITY*	CAP. CU. FT.	SHIP CU. FT.	SHIP WT. LB/KG
	L	D	H	L	D	H								
GT-30	36 <sup>15</sup> / <sub>16</sub>	32 <sup>3</sup> / <sub>16</sub>	39 <sup>3</sup> / <sub>8</sub>	938	864	1000	115	9.9	1/2	1	6	7.2	43.0	435/198
GT-40	48 <sup>5</sup> / <sub>8</sub>	32 <sup>3</sup> / <sub>16</sub>	39 <sup>3</sup> / <sub>8</sub>	1235	864	1000	115	9.9	1/2	2	8	10.0	50.0	470/214
GT-50	60 <sup>3</sup> / <sub>8</sub>	32 <sup>3</sup> / <sub>16</sub>	39 <sup>3</sup> / <sub>8</sub>	1533	864	1000	115	10.1	3/4	2	10	13.5	60.0	530/241
GT-60	72 <sup>5</sup> / <sub>16</sub>	32 <sup>3</sup> / <sub>16</sub>	39 <sup>3</sup> / <sub>8</sub>	1837	864	1000	115	10.3	3/4	2	12	17.4	71.0	585/266
GT-80	95 <sup>15</sup> / <sub>16</sub>	32 <sup>3</sup> / <sub>16</sub>	39 <sup>3</sup> / <sub>8</sub>	2437	864	1000	115	12.0	3/4	3	16	25.5	92.0	705/320

\*Baskets are optional and measure 9.125" x 12" x 7.125" deep.

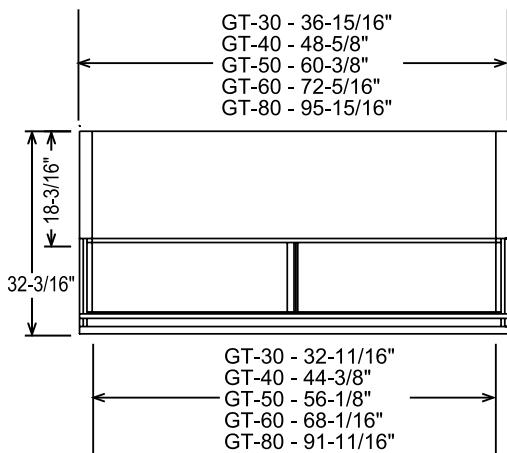

PLAN VIEW

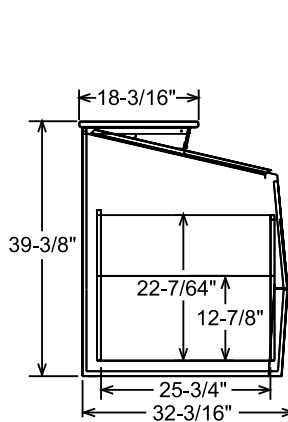

SIDE VIEW

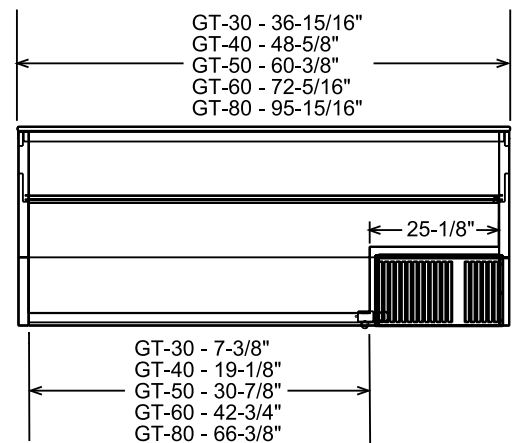

ELEVATION VIEW

### LISTINGS



### HOOKUP

Via plug in, 9 foot long, flexible 3 wire 14/3 cord with molded plug.



### BID SPECIFICATIONS

Item no. GT-\_\_\_\_\_  
 Provide \_\_\_\_\_ ( )  
 Low Temp Horizontal Display Merchandiser(s), Master-Bilt model no. GT-\_\_\_\_\_.

Merchandiser to have tempered, heat reflective glass lids with self-closing and hold-open features, mirrored finish stainless steel light shield, protective front bumper and front air discharge compressor

compartment. Merchandiser will also be equipped with high output T8HO lamps and electronic ballasts for greater energy efficiency.

The refrigeration system will contain a self-contained, slide out hermetic compressor, automatic condensate evaporator and have cold wall and gravity coil evaporator. Additionally, merchandiser is to feature a low maintenance bare tube condenser coil.

The temperature range will be 0° to -20°F (-18° to -29°C).

Merchandiser to have standard limited four year extended compressor warranty and one year limited parts and labor warranty. Merchandiser to be UL, C-UL and NSF listed.

NOTE: Cabinet designed for optimum performance in air-conditioned area at 75°F ambient and 55% relative humidity. All specifications subject to change without notice.



908 Highway 15 North • New Albany, MS 38652  
 PHONE: 800-647-1284 or 662-534-9061 • FAX: 800-232-3966 or 662-534-6049 • www.master-bilt.com

