

ITEM NO. _____
PROJECT _____
LOCATION _____
DATE _____ QTY. _____



MNR522SSG/0

MNR SERIES Top Mounted Glass Door Reach-In Refrigerators

MODELS

- MNR241SSG/0
- MNR522SSG/0
- MNR803SSG/0



FEATURES

STANDARD ELECTRONIC CONTROL

- Increases efficiency, reliability and convenience
- Allows user to easily monitor and adjust defrost functions from the panel interface on the front of the merchandiser
- Decreases service time and calls
- Eliminates cabinet thermostat, defrost timer and digital thermometer or other temperature indicator

CONSTRUCTION

- Exterior front and sides are stainless steel
- Exterior top, bottom and back are galvanized steel
- All exterior joints and seams fold in without lap joints
- Interior liner is stainless steel
- 2" foamed-in-place polyurethane insulated walls

- 4" diameter casters (4 on one- and two-door models, 6 on three-door models with 2 locking)
- Three heavy-duty epoxy-coated shelves per section
- Interior fluorescent lights activated by manual switch

DOORS

- Available with lefthand or righthand door swing
- Hold-open feature
- Each glass door provides 9.6 sq. ft. of clear glass viewing space
- Glass is tempered double pane
- Heavy-duty pivot hinges
- Centered key locks
- Pull handles
- Self-adjusting magnetic gaskets
- Complete perimeter, anti-condensate door opening heater wires

REFRIGERATION

- Top mounted, self-contained refrigeration system

- Refrigerant: R-134a
- Automatic defrost
- Automatic energy efficient hot gas condensate evaporator
- Refrigerant controlled by capillary tube
- Minimum 4" clearance required on top, rear and sides of cabinet
- Temperature range: 34° to 41°F (1° to 5°C)

WARRANTY

- Standard limited three year extended compressor and two year limited parts and labor

OPTIONS

- Extra epoxy-coated shelves
- Extra stainless steel shelves
- Full door pan slides
- Half door pan slides
- Legs in lieu of casters

TECHNICAL SPECIFICATIONS

MODEL	DIMENSIONS (in.)			DIMENSIONS (mm)			VOLTS	AMPS	UNIT H.P.	NO. OF DOORS	NO. OF SHELVES	STANDARD SHELF SIZE (in inches)	CAP. CU. FT.	SHIP CU. FT.	SHIP WT. LB/KG
	L	D	H*	L	D	H*									
MNR241SSG/0	27 ¹ / ₂	35 ¹ / ₂	81 ¹ / ₂	699	902	2070	115	4.9	1/4	1	3	23L x 28D	24.0	55.2	365/166
MNR522SSG/0	55	35 ¹ / ₂	81 ¹ / ₂	1397	902	2070	115	8.0	1/3	2	6	24 ¹ / ₂ L x 28D	51.9	105.3	545/248
MNR803SSG/0	82 ¹ / ₂	35 ¹ / ₂	81 ¹ / ₂	2096	902	2070	115	9.1	1/2	3	9	24 ¹ / ₂ L x 28D	79.9	153.4	750/341

*Height includes casters. With optional 6" legs overall height is 82³/₄"

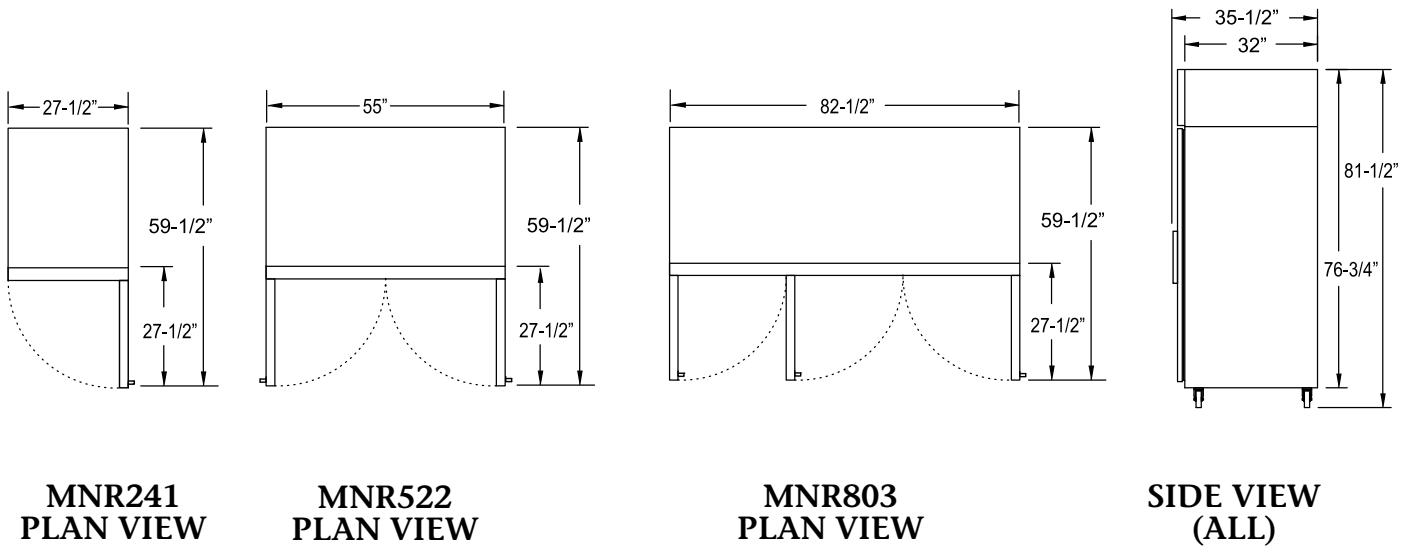

LISTINGS



HOOKUP

Via plug in, 10 foot long flexible three wire 14/3 cord with molded plug.

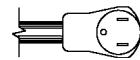

NEMA 5-15P

BID SPECIFICATIONS

Item no. MNR _____
Provide _____ () Top Mounted Glass Door Reach-in Refrigerator(s), Master-Bilt model no. MNR _____.

Reach-in will be equipped with an electronically controlled monitoring system and will feature stainless steel exterior front and sides. The exterior top, bottom and back will be galvanized steel while the interior liner will be stainless steel.

Each glass door provides 9.6 sq. ft. of

clear glass viewing space. Door glass is tempered thermopane. Doors will also feature heavy-duty pivot hinges and centered key locks. Anti-condensate door opening heater wires line the complete perimeter of each door.

The refrigeration system will be top mounted and self-contained. The refrigerant will be R-134a and the temperature range will be 34° to 41°F (1° to 5°C). The refrigeration system will also feature au-

tomatic defrost and an automatic energy efficient hot gas condensate evaporator. Refrigerant will be controlled by capillary tube.

Reach-in to have standard limited three year extended compressor warranty and two year limited parts and labor warranty.

Reach-in to be UL and C-UL listed, UL EPH classified and California Energy Code certified.

NOTE: Cabinet designed for optimum performance in air-conditioned area at 75°F ambient and 55% relative humidity. All specifications subject to change without notice.