

ITEM NO. _____
 PROJECT _____
 LOCATION _____
 DATE _____ QTY. _____



MPR SERIES Pass-Thru Refrigerators

MODELS

- MPR242
- MPR524
- MPR806



NOTE:

- CEC certification applies to models with full solid doors only.
- Models with glass doors on both sides are not UL EPH classified to NSF 7.

FEATURES

STANDARD ELECTRONIC CONTROL

- Increases efficiency, reliability and convenience
- Allows user to easily monitor and adjust defrost functions from the panel interface on the front of the merchandiser
- Decreases service time and calls
- Eliminates cabinet thermostat, defrost timer and digital thermometer or other temperature indicator

CONSTRUCTION

- Exterior front, sides and doors are stainless steel
- Exterior top and bottom are galvanized steel
- All exterior joints and seams fold in without lap joints
- Interior liner and door panel are stainless steel
- 2" foamed-in-place polyurethane insulated walls

- 4" diameter casters (4 on one- and two-section models, 6 on three-section model)
- Three heavy-duty epoxy-coated shelves per section
- Interior LED light activated by switches for each door

DOORS

- Available with lefthand or righthand door swing
- Heavy-duty pivot hinges
- Centered key locks
- Horizontal handles
- Self-adjusting magnetic gaskets

REFRIGERATION

- Top mounted, self-contained refrigeration system
- Refrigerant: R-134a
- Automatic defrost
- Automatic energy efficient hot gas condensate evaporator
- Refrigerant controlled by thermostatic expansion valve
- Minimum 4" clearance required on top, rear and sides of cabinet

- Temperature range: 34° to 41°F (1° to 5°C)

WARRANTY

- Standard limited three year extended compressor and two year limited parts and labor

OPTIONS

- Extra epoxy-coated shelves
- Extra stainless steel shelves
- Full door pan slides
- Half door pan slides
- Full glass doors
- Half glass doors
- Half solid doors
- Legs in lieu of casters

TECHNICAL SPECIFICATIONS

MODEL	DIMENSIONS (in.)			DIMENSIONS (mm)			VOLTS	AMPS	UNIT H.P.	NO. OF DOORS	NO. OF SHELVES	STANDARD SHELF SIZE (in inches)	CAP. CU. FT.	SHIP CU. FT.	SHIP WT. LB/KG
	L	D	H*	L	D	H*									
MPR242	27 ¹ / ₂	38 ¹ / ₄	81 ¹ / ₂	699	972	2070	115	8.6	1/3	2	3	23L x 28D	25.6	55.2	470/214
MPR524	55	38 ¹ / ₄	81 ¹ / ₂	1397	972	2070	115	10.7	1/2	4	6	24 ¹ / ₂ L x 28D	55.7	105.3	758/345
MPR806	82 ¹ / ₂	38 ¹ / ₄	81 ¹ / ₂	2096	972	2070	115	10.4	3/4	6	9	24 ¹ / ₂ L x 28D	85.8	153.4	921/419

*Height includes casters. With optional 6" legs overall height is 82³/₄"

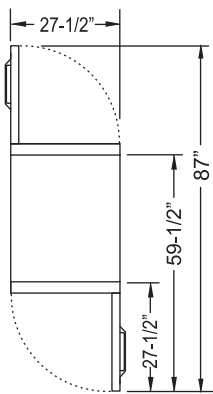

**MPR242
PLAN VIEW**

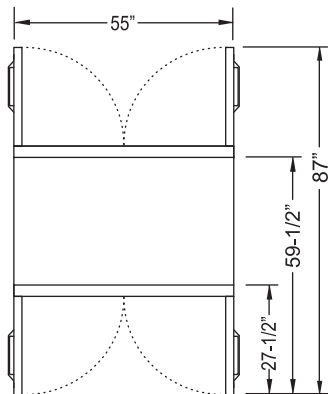

**MPR524
PLAN VIEW**

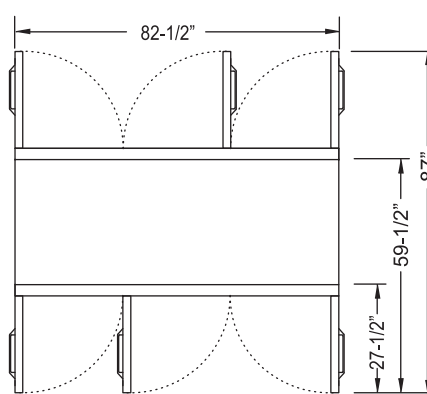

**MPR806
PLAN VIEW**

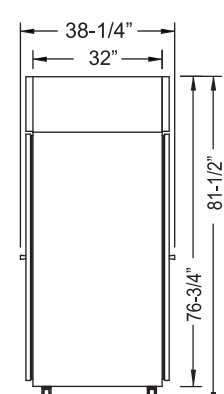

**SIDE VIEW
(ALL)**

LISTINGS



NOTE:

- CEC certification applies to models with full solid doors only.
- Models with glass doors on both sides are not UL EPH classified to NSF 7.

HOOKUP

Via plug in, 10 foot long flexible three wire 14/3 cord with molded plug.

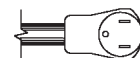

NEMA 5-15P

BID SPECIFICATIONS

Item no. MPR _____
Provide _____ () Pass-Thru Refrigerator(s), Master-Bilt model no. MPR _____.

Pass-thru refrigerator will be equipped with an electronically controlled monitoring system and will feature stainless steel exterior front, sides and doors. The exterior top and bottom will be galvanized steel while the interior liner and door panel will be stainless steel. Also standard will be an

interior LED light activated by switches for each door as well as a digital thermometer.

Doors will feature heavy-duty pivot hinges and centered key locks.

The refrigeration system will be top mounted and self-contained. The refrigerant will be R-134a and the temperature range will be 34° to 41°F (1° to 5°C).

The refrigeration system will also feature automatic defrost and an automatic energy efficient hot gas condensate evaporator. Re-

frigerant controlled by thermostatic expansion valve.

Pass-thru to have standard limited three year extended compressor warranty and two year limited parts and labor warranty.

Pass-thru to be UL and C-UL listed and UL EPH classified (except for models with glass doors on both sides). California Energy Code certification will apply to models with full solid doors.

NOTE: Cabinet designed for optimum performance in air-conditioned area at 75°F ambient and 55% relative humidity. All specifications subject to change without notice.