



QMVM-48E

## QMVM SERIES

### Quantum Series Medium Temp Vertical Open Display Merchandisers

#### MODELS

- QMVM-36E
- QMVM-48E
- QMVM-72E

## FEATURES

### STANDARD ELECTRONIC CONTROL

- Allows user to easily monitor defrost functions from the panel interface on the front of the merchandiser
- Audible and visual alarm
- Decreases service time and calls
- Eliminates room thermostat, defrost termination/fan delay control, defrost timer and digital thermometer or other temperature indicator

### CONSTRUCTION

- 24 gauge galvanized steel exterior and interior
- 2" foamed-in-place "zero ODP" urethane insulation
- Shelves adjustable in 1" increments
- Three lighted tiers of two-position shelving with price tag molding
- Perforated interior back wall and top for better air flow
- Electric defrost
- Easily accessible electrical enclosure

### FINISH

- White enamel interior and exterior
- Stainless steel floor pans (removable for easy service)

### REFRIGERATION

- Refrigerant: R-404A
- Front air intake and rear air discharge
- Self-contained, bottom mount refrigeration system
- Minimum of 6" clearance between cabinet back and wall and a clearance of 10" at top
- Temp. range: 34° to 41°F (1° to 5°C)
- R-factor (insulation efficiency rating): 17.24
- Drain plumbing hookup recommended. Condensate pan available if there is no access to drain plumbing. Condensate pan must be field installed and requires a dedicated 15 amp, 120 volt circuit.

### WARRANTY

- Standard limited three year extended compressor and two year limited parts and labor

## OPTIONS

- Add suffix "R" for remote system (QMVM-48E and -72E only)
- Add suffix "ESS" for stainless steel interior and exterior
- Custom exterior colors
- Condensate evaporator drain pan  
*NOTE: Must be field installed and requires a dedicated 15A, 120v circuit.*
- Condensate pump
- Product hooks
- Casters
- Extra lighted shelves (one only)
- Extra non-lighted shelves
- 1" vinyl bumper in choice of black, blue, brown, green, red or white
- Vinyl retractable night curtain
- Locking metal night curtain (less locks)



# QMVM SERIES

## QUANTUM SERIES MEDIUM TEMP VERTICAL OPEN DISPLAY MERCHANDISERS

### TECHNICAL SPECIFICATIONS

MODEL	DIMENSIONS (in.)			DIMENSIONS (mm)			VOLTS	AMPS*	UNIT H.P.	NO. OF SHELVES	STANDARD SHELF WIDTH (in inches)	CAP. CU. FT.	SHIP CU. FT.	SHIP WT. LB/KG
	L	D	H	L	D	H								
QMVM-36E	36	30	81	914	762	2057	208-230	13.5	1	3	14 x 31 <sup>1</sup> / <sub>8</sub>	13.6	89.0	525/239
QMVM-48E	48	30	81	1219	762	2057	208-230	16.1	1	3	14 x 43 <sup>1</sup> / <sub>8</sub>	20.4	107.0	640/291
QMVM-72E	72	30	81	1829	762	2057	115/208-230	3.7/13.7	1 <sup>1</sup> / <sub>2</sub>	6	14 x 33 <sup>1</sup> / <sub>16</sub>	31.5	152.0	860/391

\*If condensate evaporator pan accessory is used, it must be field installed and requires a dedicated 15 amp, 120 volt circuit.

**Note: 208-230/60/1 also requires neutral and safety ground wire.**

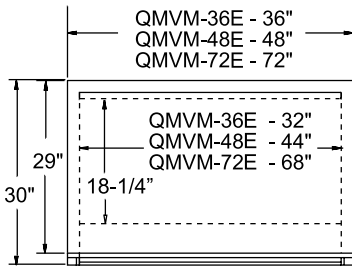

PLAN VIEW

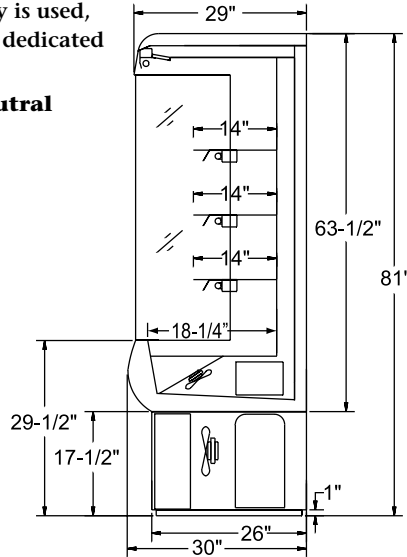

SIDE VIEW

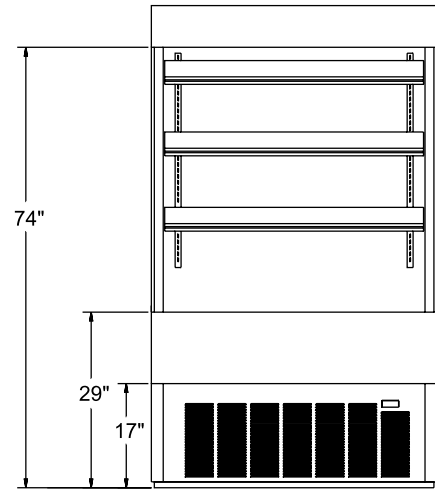

ELEVATION VIEW

### LISTINGS



### HOOKUP

Electrical: QMVM-36E and QMVM-48E via plug in, 9 foot long flexible four wire 208-230v 14/4 cord with neutral and ground wires and molded plug. QMVM-72E is a hardwire.

Plumbing: Requires connection to customer's drain

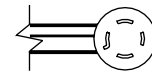

NEMA L14-20P (QMVM-36E & QMVM-48E)

### RECOMMENDED OPERATING CONDITIONS

- Merchandisers designed to hold product in the 34° to 41°F (1° to 5°C) range
- Designed to operate in air-conditioned stores where the maximum temperature is 75°F and the maximum relative humidity is 55%
- Should not be installed in direct sunlight
- Should not be installed near HVAC vents, fans or doorways that will disrupt airflow and compromise the function of the air screen inside the case
- Bottom shelf should not be loaded such that the front air intake is obstructed
- Floor drain should be properly trapped
- Factory installed controls should not be altered, removed or replaced without consent of the factory
- Product must not be displayed in the cold air curtain

### BID SPECIFICATIONS

Item no. QMVM-\_\_\_\_\_  
Provide \_\_\_\_\_ ( ) Quantum Series Medium Temp Vertical Open Display Merchandiser(s), Master-Bilt model no. QMVM-\_\_\_\_\_.

Merchandiser to have standard electronic controller eliminating the need for a room thermostat, defrost termination/fan delay control, defrost timer and digital thermom-

eter or other temperature indicator.

Other features will include adjustable two-position shelves, independent shelf lighting, perforated interior back wall, electric defrost and 2" foamed-in-place "zero ODP" urethane insulation.

The refrigeration system is to be self-contained, have a front condenser air intake and rear air discharge and use R-404A refrigerant.

The temperature range will be 34° to 41°F (1° to 5°C).

Merchandiser to have standard limited three year extended compressor warranty and two year limited parts and labor warranty.

Merchandiser to be UL and C-UL listed and UL EPH classified.



908 Highway 15 North • New Albany, MS 38652

PHONE: 800-647-1284 or 662-534-9061 • FAX: 800-232-3966 or 662-534-6049 • www.master-bilt.com

All specifications subject to change without notice.

