



TLG-48HD

The only top mounted glass door reach-ins with low maintenance bare tube condenser coils

TLG SERIES

Top Mounted Low Temp Glass Door Merchandisers

MODELS

- TLG-27HD
- TLG-48HD
- TLG-52HD
- TLG-74HD
- TLG-80HD

FEATURES

STANDARD ELECTRONIC CONTROL

- Allows user to easily monitor defrost functions from the panel interface on the front of the merchandiser
- Audible and visual alarm
- Decreases service time and calls
- Eliminates room thermostat, defrost termination/fan delay control, defrost timer and digital thermometer or other temperature indicator

CONSTRUCTION

- 24 gauge white polyester painted steel interior and exterior
- Single cord and plug standard on all self-contained models
- Replaceable magnetic vinyl door gaskets
- 6"-7" adjustable metal legs
- Five white epoxy-coated, heavy-duty welded wire shelves (four cantilever,

one bottom) with price tag molding per door

- Cantilever shelves are two-position and adjustable in 1" increments
- Equipped with high output T8HO lamps and electronic ballasts for greater energy efficiency
- Independent on/off light switch
- 2" foamed-in-place "zero ODP" urethane insulation

DOORS

- Extra large, auto-close, triple pane, with heated safety glass and heated frames
- Black door rails and handles
- Adjustable torsion bar hinges
- Door hinges easily adjustable for closing tension and leveling

REFRIGERATION

- Self-contained, factory tested, slide out refrigeration system
- Electric condensate evaporator
- Top mounted low profile interior fan housing
- Refrigerant: R-404A

- Minimum 6" clearance required between cabinet back and wall
- Temperature range: 5° to -15°F (-18° to -26°C)
- R-factor (insulation efficiency rating): 17.24

WARRANTY

- Standard limited three year extended compressor and two year limited parts and labor

OPTIONS

- Add suffix "R" for remote system (available on TLG-48HD and TLG-74HD only)
- Add suffix "QC" for quick couple system
- Custom exterior colors
- Baskets
- Extra shelves
- Voltage boosting transformer
- Casters



TLG SERIES

TOP MOUNTED LOW TEMP GLASS DOOR MERCHANDISERS

TECHNICAL SPECIFICATIONS

MODEL	DIMENSIONS (in.)			DIMENSIONS (mm)			VOLTS**	AMPS	UNIT H.P.	NO. OF DOORS	CAP. CU. FT.	SHIP CU. FT.	SHIP WT. LB/KG
	L	D	H*	L	D	H							
TLG-27HD	31	35 ³ / ₄	85	787	908	2159	115	16.5	3/4	1	27.5	79.0	600/273
TLG-48HD	52	35 ³ / ₄	85	1321	908	2159	208-230	11.9	1 ¹ / ₂	2	49.0	118.7	830/377
TLG-52HD	56	35 ³ / ₄	85	1422	908	2159	208-230	11.9	1 ¹ / ₂	2	53.0	128.0	850/386
TLG-74HD	78	35 ³ / ₄	85	1981	908	2159	208-230	12.4	2	3	75.5	168.0	1085/493
TLG-80HD	84	35 ³ / ₄	85	2134	908	2159	208-230	12.4	2	3	81.6	185.0	1100/500

*Height includes 6"-7" adjustable legs. **TLG models (except TLG-27HD) operate on a minimum of 208 volts. A voltage boosting transformer (part no. 39-01087) must be used when the supply voltage is less than 208 volts. **Note: 208-230/60/1 also requires neutral and safety ground wire.**

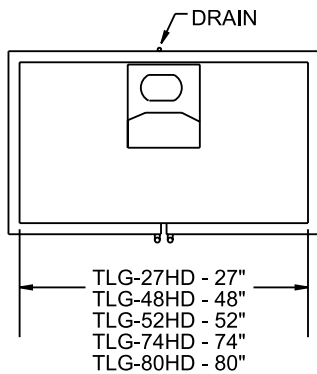

PLAN VIEW

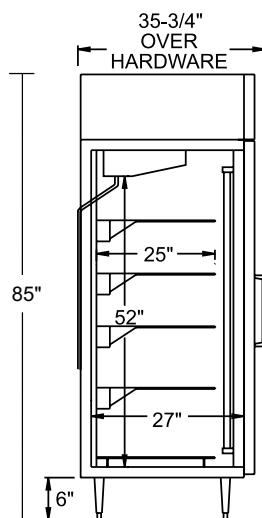

SIDE VIEW

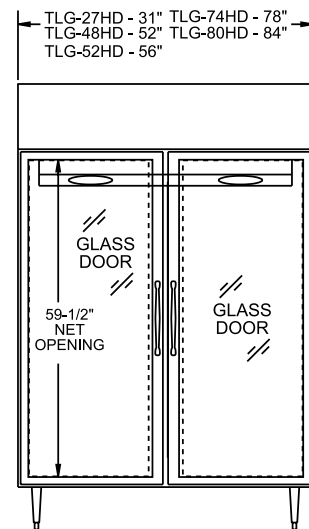

ELEVATION VIEW

LISTINGS



HOOKUP

TLG-27HD: Via plug in, 9 foot long flexible three wire 14/3 cord with molded plug.

Other models: Via plug in, 9 foot long flexible four wire 208-230v 14/4 cord with neutral and ground wires and molded plug.

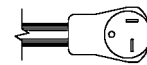

NEMA 5-20P (TLG-27HD ONLY)

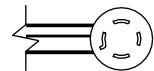

NEMA L14-20P (ALL OTHER MODELS)

BID SPECIFICATIONS

Item no. TLG-____HD.
Provide _____ () Top Mounted Low Temp Glass Door Merchandiser(s), Master-Bilt model no. TLG-____HD.

Merchandiser will be equipped with an electronically controlled monitoring system. It will also be provided with top mounted low profile interior fan housing, electric condensate evaporator, rear wall

guard and metal legs with 6"-7" adjustable range. Merchandiser will be equipped with five white epoxy-coated shelves (four cantilever and one bottom) with price tag molding per door.

Doors will contain black rails and handles, triple pane glass, adjustable torsion-bar hinges and heated frames and door openings.

The refrigeration system will be top mounted, self-contained and use R-404A refrigerant. The system will contain a low maintenance bare tube condenser coil. The temperature range will be 5° to -15°F (-18° to -26°C)

Merchandiser to have standard limited three year extended compressor warranty and two year limited parts and labor warranty. Merchandiser to be UL, C-UL and NSF listed.

NOTE: Cabinet designed for optimum performance in air-conditioned area at 75°F ambient and 55% relative humidity. All specifications subject to change without notice.



908 Highway 15 North • New Albany, MS 38652
PHONE: 800-647-1284 or 662-534-9061 • FAX: 800-232-3966 or 662-534-6049 • www.master-bilt.com

