



BLG-12HD

BLG-12HD SERIES

Bottom Mounted Low Temp Low Profile Glass Door Merchandisers

MODELS

- BLG-12HD

FEATURES

NEW STANDARD TEXTURED FINISH



Standard white

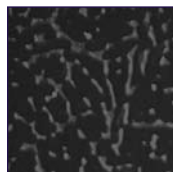

Black also available

CONSTRUCTION

- Standard electronic controller that decreases service time and calls. Controller eliminates room thermostat, defrost termination/fan delay control, defrost timer and digital thermometer or other temperature indicator
- 24 gauge painted galvanized steel interior and exterior
- Equipped with two high output T8HO lamps and electronic ballasts for greater energy efficiency

- Three white epoxy-coated, heavy-duty welded wire shelves with price tag molding
- Independent on/off light switch
- Rear wall guard
- 2" foamed-in-place "zero ODP" urethane insulation

FINISH

- Sparkling white textured polyester enamel interior and exterior

DOORS

- Auto-close, triple pane, heated safety glass door with heated frame
- 90° hold-open feature
- Door size: 28³/₈" x 36¹/₄"
- Black door rails and handles
- Adjustable torsion bar hinges
- Replaceable magnetic vinyl door gaskets
- Door hinges easily adjustable for closing tension and leveling

REFRIGERATION

- Refrigerant: R-404A

- Self-contained, bottom mounted, factory tested refrigeration system
- Top mounted, low profile interior fan housing
- Automatic condensate evaporator
- Minimum 6" clearance required between cabinet back and wall
- Temperature range: 5° to -15°F (-18° to -26°C)
- R-factor (insulation efficiency rating): 17.24

WARRANTY

- Standard limited three year extended compressor and two year limited parts and labor

OPTIONS

- Custom exterior colors
- Casters
- Legs
- Additional shelves



BLG-12HD SERIES

BOTTOM MOUNTED LOW TEMP LOW PROFILE GLASS DOOR MERCHANDISERS

TECHNICAL SPECIFICATIONS

MODEL	DIMENSIONS (in.)			DIMENSIONS (mm)			VOLTS	AMPS	UNIT H.P.	NO. OF DOORS	CAP. CU. FT.	SHIP CU. FT.	SHIP WT. (LB/KG)
	L	D	H	L	D	H							
BLG-12HD	31	35 ³ / ₄	53 ⁷ / ₈	787	908	1368	115	13.9	3/4	1	12.5	45.5	450/205

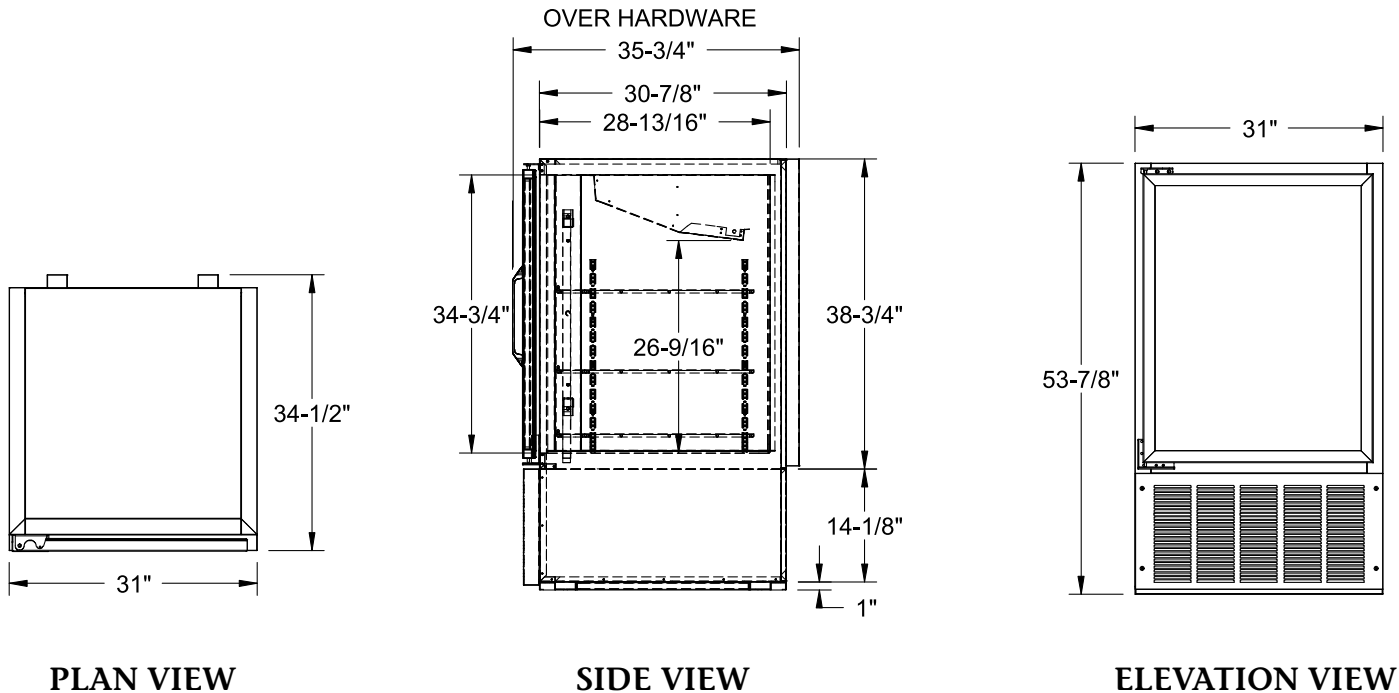

LISTINGS



HOOKUP

Via plug in, 9 foot long flexible three wire 14/3 cord with molded plug.



BID SPECIFICATIONS

Item no. BLG-12
Provide _____ () Bottom Mounted Low Temp Low Profile Glass Door Merchandiser(s), Master-Bilt model no. BLG-12.

Merchandiser will feature textured finish on interior and exterior and will be equipped with an electronically controlled monitoring system. It will also be provided

with adjustable torsion bar hinges, heated frames and door openings, top mounted low profile interior fan housing, automatic condensate evaporator, three white epoxy-coated shelves with price tag molding per door, energy efficient T8HO lamps, independent on/off light switch, black door rails and handles and triple pane glass.

The refrigeration system is to be bottom

mounted, self-contained and use R-404A refrigerant. The temperature range will be 5° to -15°F (-15° to -26°C).

Merchandiser to have standard limited three year extended compressor warranty and two year limited parts and labor warranty. Merchandiser to be UL, C-UL and NSF listed.

NOTE: Cabinet designed for optimum performance in air-conditioned area at 75°F ambient and 55% relative humidity. All specifications subject to change without notice.



908 Highway 15 North • New Albany, MS 38652
PHONE: 800-647-1284 or 662-534-9061 • FAX: 800-232-3966 or 662-534-6049 • www.master-bilt.com