



## DC SERIES

### Conventional Ice Cream Storage/Dipping Cabinets

#### MODELS

- |                                |                                 |
|--------------------------------|---------------------------------|
| <input type="checkbox"/> DC-2S | <input type="checkbox"/> DC-8D  |
| <input type="checkbox"/> DC-4S | <input type="checkbox"/> DC-10D |
| <input type="checkbox"/> DC-4D | <input type="checkbox"/> DC-12D |
| <input type="checkbox"/> DC-6D |                                 |

## FEATURES

### CONSTRUCTION

- Seamless stainless steel top
- 24 gauge white painted galvanized steel cabinet
- Equipped with leveling legs to correct for unlevel flooring situations
- Floor drain with garden hose fitting
- Galvanized steel inner liner with cold wall evaporator
- Anti-condensate heaters under stainless top cap
- 2 1/4" foamed-in-place "zero ODP" urethane insulation

### FINISH

- Baked-on white polyester enamel exterior finish with galvanized steel interior

### LIDS

- Stainless steel
- Hinged with handles
- Gasket

### REFRIGERATION

- Refrigerant:  
 DC-12D ..... R-404A  
 All other models ..... R-134a
- Self-contained, factory tested refrigeration system
- Force draft hermetic condensing unit (semi-hermetic unit on DC-12D with wire and tube condenser for low maintenance)
- Minimum 4" clearance required between cabinet back and wall
- Temperature range:  
 10° to -10°F (-12° to -23°C)
- R-factor (insulation efficiency rating): 19.40

### WARRANTY

- Standard limited four year extended compressor and one year limited parts and labor

## OPTIONS

- Add suffix "SE" for all-stainless exterior
- Custom colors
- Lid locks
- Legs
- Casters
- Additional lids
- Load level shelves
- Dipper well



# DC SERIES

## CONVENTIONAL ICE CREAM STORAGE/DIPPING CABINETS

### TECHNICAL SPECIFICATIONS

MODEL	DIMENSIONS (in.)			DIMENSIONS (mm)			VOLTS	AMPS	UNIT H.P.	CAN CAP. DISPLAY/STORAGE*	CAP. CU. FT.	SHIP CU. FT.	SHIP WT. LB/KG
	L	D	H	L	D	H							
DC-2S	31 <sup>7</sup> / <sub>8</sub>	21 <sup>1</sup> / <sub>8</sub>	34 <sup>1</sup> / <sub>8</sub>	810	537	867	115	5.7	1/4	2/1	5.2	19.0	195/89
DC-4S	54	21 <sup>1</sup> / <sub>8</sub>	34 <sup>1</sup> / <sub>8</sub>	1372	537	867	115	5.7	1/4	5/4	11.0	36.0	280/127
DC-4D	30 <sup>5</sup> / <sub>8</sub>	30 <sup>1</sup> / <sub>8</sub>	34 <sup>1</sup> / <sub>8</sub>	778	765	867	115	5.7	1/4	5/2	7.6	27.0	220/100
DC-6D	43	30 <sup>1</sup> / <sub>8</sub>	34 <sup>1</sup> / <sub>8</sub>	1092	765	867	115	5.7	1/4	8/5	12.5	39.0	275/125
DC-8D	54	30 <sup>1</sup> / <sub>8</sub>	34 <sup>1</sup> / <sub>8</sub>	1372	765	867	115	7.3	1/3	11/8	17.3	47.0	365/164
DC-10D	66 <sup>5</sup> / <sub>8</sub>	30 <sup>1</sup> / <sub>8</sub>	34 <sup>1</sup> / <sub>8</sub>	1692	765	867	115	7.3	1/3	14/11	22.0	59.0	430/195
DC-12D	84 <sup>5</sup> / <sub>8</sub>	30 <sup>1</sup> / <sub>8</sub>	34 <sup>1</sup> / <sub>8</sub>	2149	765	867	115	7.5	1/3**	18/15	29.1	71.0	490/223

\*Capacity in 3 gal. cans \*\*Semi-hermetic compressor

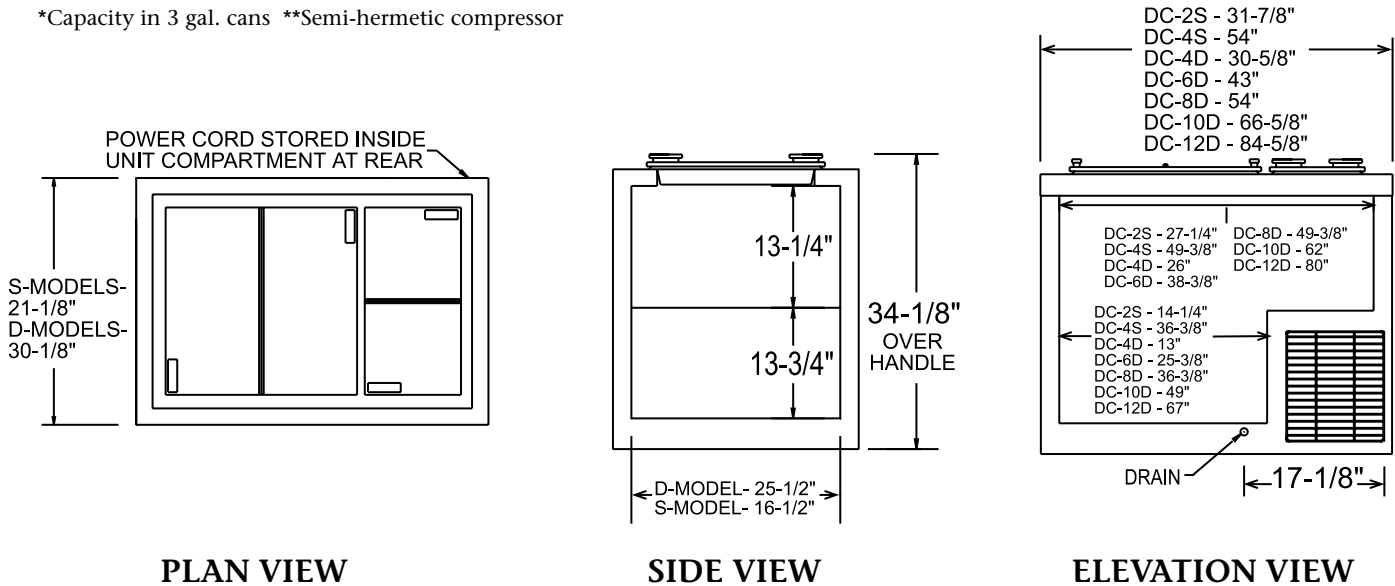

### LISTINGS



C-UL listing for all models except DC-12D.

### HOOKUP

Via plug in, 9 foot long, flexible 3 wire 14/3 cord with molded plug. Ten amp 115V service is recommended.



### BID SPECIFICATIONS

Item no. DC-\_\_\_\_\_

Provide \_\_\_\_\_ ( ) Conventional Ice Cream Storage/Dipping Cabinet(s), Master-Bilt model DC-\_\_\_\_\_.

Cabinet to have flip lids, seamless stainless steel top, 24 gauge steel walls, galvanized steel inner liner with cold wall evaporator, anti-condensate heaters

under stainless steel top, 2 1/4" foamed-in-place "zero ODP" urethane insulation and baked-on polyester enamel finish. Standard leveling legs provided to correct for unlevel flooring situations.

The refrigeration system will be self-contained. DC-12D will contain R-404A refrigerant and all other models will contain

R-134a. The temperature range will be 10° to -10°F (-12° to -23°C).

Cabinet to have standard limited four year extended compressor warranty and one year limited parts and labor warranty.

Cabinet to be UL, C-UL (on all except DC-12D) and NSF listed.

**NOTE:** Cabinet designed for optimum performance in air-conditioned area at 75°F ambient and 55% relative humidity. All specifications subject to change without notice.



908 Highway 15 North • New Albany, MS 38652  
 PHONE: 800-647-1284 or 662-534-9061 • FAX: 800-232-3966 or 662-534-6049 • www.master-bilt.com

