



DOMC-124

DOMC SERIES

Cold Wall Evaporator Dual Access Milk Coolers

MODELS

- DOMC-084
- DOMC-124
- DOMC-164

FEATURES

CONSTRUCTION

- White enamel painted steel exterior
- Galvanized steel interior including door interior
- Dual access to allow serving of two feeding lines
- Four 4" easy-roll swivel casters (two locking)
- Epoxy-coated heavy-duty floor racks (stainless steel option available)
- Reinforced base to maintain cooler integrity when fully loaded
- NSF-listed floor drain
- NSF-listed thermometer
- 2 1/2" fiberglass insulation
- Doors and cabinet top foamed-in-place with polyurethane insulation

DOORS

- Self service doors with stainless steel exterior
- Doors are fold-back type
- Doors equipped with locks, gaskets and stainless steel hinges
- Designed to be easily opened by children for self-service
- Hold-open feature secures door during serving

REFRIGERATION

- Self-contained, bottom mount
- Powerful, large-capacity system allows cooler to maintain proper temperature for longer amount of time with doors open

- Cold wall evaporator with no moving parts which allows more storage space
- Back of cabinet may be placed against wall but there must be a minimum 4" clearance between cabinet sides and wall
- Refrigerant: R-134A
- Operating temperature: 38°F (3°C)

WARRANTY

- Standard limited three year extended compressor and two year limited parts and labor

CAPACITY

MODEL	CASES WITH CARTONS				LOOSE CARTON (WITHOUT CASES)	
	13" x 13" x 11"H		19" x 13" x 11"H		1/2 PINT	1 PINT
	CASES	CARTONS	CASES	CARTONS		
DOMC-084	8	352	4	288	864	432
DOMC-124	12	528	8	576	1368	684
DOMC-164	16	704	12	864	1800	900

OPTIONS

- Add "SS" for stainless steel interior and exterior
- Laminate for top, front, sides and back
- (4) six-inch adjustable legs
- Stainless steel floor rack
- Corner bumpers



DOMC SERIES

COLD WALL EVAPORATOR DUAL ACCESS MILK COOLERS

TECHNICAL SPECIFICATIONS

MODEL	DIMENSIONS (in.)			DIMENSIONS (mm)			VOLTS	AMPS	UNIT H.P.	NO. OF FLOOR RACKS	CAP. CU. FT.	SHIP CU. FT.	SHIP WT. LB/KG
	L	D	H*	L	D	H*							
DOMC-084	35	35	44	889	889	1118	115	4.2	1/4	2	12.2	36.7	326/148
DOMC-124	49	35	44	1245	889	1118	115	4.3	1/4	3	17.8	49.9	352/160
DOMC-164	63	35	44	1600	889	1118	115	4.5	1/4	4	23.5	64.0	484/220

*Height includes casters.

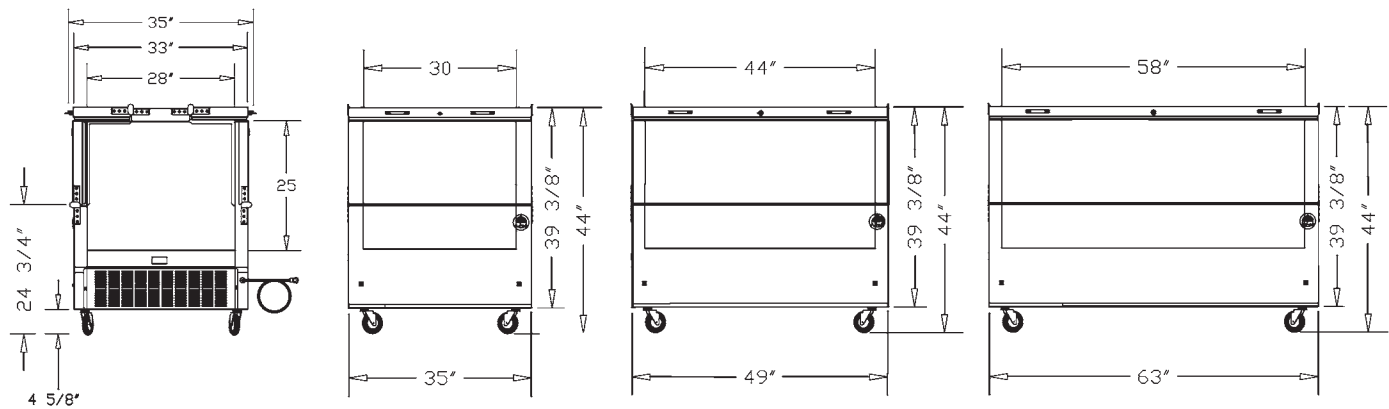

SIDE VIEW

DOMC-084 ELEVATION VIEW

DOMC-124 ELEVATION VIEW

DOMC-164 ELEVATION VIEW

LISTINGS



HOOKUP

Via plug in, 7 foot long flexible three wire 16 gauge cord with molded plug.



BID SPECIFICATIONS

Item no. DOMC- _____ Provide _____ () Cold Wall Evaporator Dual Access Milk Cooler(s), Master-Bilt model no. DOMC- _____.

Milk cooler will be a dual access type and will be constructed of white painted steel on the exterior with galvanized steel interior. Doors to be stainless steel on the exterior with galvanized steel interior. Doors will also be locking and fold-back type. In addition, door will be equipped with gaskets, stainless steel hinges and a

hold-open feature to secure during serving.

Cooler to be provided with four swivel casters (two locking) and an NSF-listed floor drain and thermometer. Additionally, cooler will contain heavy-duty epoxy-coated floor racks and a reinforced base to maintain cooler integrity when fully loaded. Cabinet insulation will consist of 2 1/2" thick fiberglass. Door and cabinet top foamed-in-place with polyurethane insulation.

The refrigeration system will be self-contained, bottom mounted with a cold wall evaporator. System will contain R-134A refrigerant. The operating temperature will be 38°F (3°C).

Cooler to have standard limited three year extended compressor warranty and two year limited parts and labor warranty.

Cooler to be UL and C-UL listed as well as UL EPH classified.

NOTE: Cabinet designed for optimum performance in air-conditioned area at 75°F ambient and 55% relative humidity. All specifications subject to change without notice.



908 Highway 15 North • New Albany, MS 38652
PHONE: 800-647-1284 or 662-534-9061 • FAX: 800-232-3966 or 662-534-6049 • www.master-bilt.com

