

TEM/TEL SERIES

Endless Remote Glass Door Merchandisers With Top Mounted Coil

MEDIUM TEMP MODELS (24" WIDE DOORS)

- TEM-3-24 TEM-5-24
 TEM-4-24 TEM-6-24

LOW TEMP MODELS (24" WIDE DOORS)

- TEL-3-24 TEL-5-24
 TEL-4-24 TEL-6-24

MEDIUM TEMP MODELS (30" WIDE DOORS)

- TEM-2-30 TEM-4-30
 TEM-3-30 TEM-5-30

LOW TEMP MODELS (30" WIDE DOORS)

- TEL-2-30 TEL-4-30
 TEL-3-30 TEL-5-30



TEL-5-30
(shown with
ends installed)



FEATURES

CONSTRUCTION

- White painted galvanized steel cabinet
- 2" foamed-in-place "zero ODP" urethane insulation
- A large heavy duty rub rail and kick plate to protect from abuse
- Five white cantilever epoxy-coated welded wire shelves with price tag molding per door
- Shelves rated to support 110 lbs. each
- Product stop feature to prevent product from falling behind shelves
- Pre-wired cabinet-to-cabinet electrical terminal block connectors
- Standard joining kits when linking together multi-door modules
- Ends must be ordered separately
- Standard TEM vertical lighting features T-12 high output bulbs while TEL models are equipped with T-10 bulbs
- Optional electronic lighting and additional horizontal lighting available, consult factory
- Pre-piped drain in bottom of each section for cleaning purposes (with removable plug)

DOORS

- Choice of 24" or 30" wide glass doors
- Self-closing door hinge with adjustable torsion control
- Standard black door and frame (optional colors available)

REFRIGERATION

- All models designed for remote refrigeration systems
- Refrigerant: R-404A
- Factory tested refrigeration system
- Oversized raceway for ease of refrigeration piping
- Full length heavy-duty copper tube evaporator coil
- Choice of electric or hot gas defrost
- Pre-mounted expansion valve
- Minimum 4" clearance required between cabinet back and wall with a 4" open space at top and one or both ends
- Temperature ranges:
 -TEM models: 34° to 41°F (1° to 5°C)
 -TEL models: 0° to -15°F (18° to -26°C)

- R-factor (insulation efficiency rating): 18.75

WARRANTY

- Two year limited parts and 90 day labor

OPTIONS

- Right or left hand end kits
 Custom colors
 Electronic lighting
 Additional horizontal lighting
 Partitions
 Kickplate
 Additional 30" cantilever shelves
 Baskets



TEM/TEL SERIES

ENDLESS REMOTE GLASS DOOR MERCHANDISERS
WITH TOP MOUNTED COIL

TECHNICAL SPECIFICATIONS

MODEL	DIMENSIONS (in.)			DIMENSIONS (mm)			NO. OF DOORS	NO. OF SHELVES	SHELVING AREA SQ. FT.	USABLE CU. FT.	PRODUCT FACING SQ. FT.	NO. OF INTERIOR LIGHTS
	L*	D	H	L*	D	H						
24" WIDE DOOR MODELS												
TEM/TEL-3-24	74 ¹ / ₄	37 ³ / ₄	80	1886	959	2032	3	15	58.0	66.0	33.0	4
TEM/TEL-4-24	98	37 ³ / ₄	80	2489	959	2032	4	20	78.0	87.0	43.0	5
TEM/TEL-5-24	121 ³ / ₄	37 ³ / ₄	80	3092	959	2032	5	25	97.0	108.0	54.0	6
TEM/TEL-6-24	145 ¹ / ₂	37 ³ / ₄	80	3696	959	2032	6	30	116.0	129.0	64.0	7
30" WIDE DOOR MODELS												
TEM/TEL-2-30	63 ¹ / ₂	37 ³ / ₄	80	1613	959	2032	2	10	49.0	56.0	23.0	3
TEM/TEL-3-30	94 ¹ / ₂	37 ³ / ₄	80	2400	959	2032	3	15	73.0	84.0	42.0	4
TEM/TEL-4-30	124 ¹ / ₂	37 ³ / ₄	80	3162	959	2032	4	20	97.0	110.0	55.0	5
TEM/TEL-5-30	155	37 ³ / ₄	80	3937	959	2032	5	25	122.0	137.0	68.0	6

*Add 2" (51mm) to length for each end or insulated partition.

NOTE: All models furnished with R-404A expansion valve unless otherwise specified.

ELECTRICAL

MODEL	120 VOLT - 1 PHASE				230 VOLT - 1 PHASE		
	LIGHTS (LED)	LIGHTS (ELS)	HEATERS	FANS	FANS	DEFROST	
MEDIUM TEMP 24" WIDE DOORS							
TEM-3-24	0.85	1.9	2.74	1.4	N/A	N/A	
TEM-4-24	1.13	2.4	3.57	1.4	N/A	N/A	
TEM-5-24	1.42	2.9	4.48	2.1	N/A	N/A	
TEM-6-24	1.7	3.4	5.23	2.1	N/A	N/A	
MEDIUM TEMP 30" WIDE DOORS							
TEM-2-30	0.57	1.5	2.09	1.4	N/A	N/A	
TEM-3-30	0.85	1.9	3.04	1.4	N/A	N/A	
TEM-4-30	1.13	2.4	3.89	2.1	N/A	N/A	
TEM-5-30	1.42	2.9	4.91	2.1	N/A	N/A	
LOW TEMP 24" WIDE DOORS							
TEL-3-24	0.85	1.9	5.47	N/A	0.6	5.52	
TEL-4-24	1.13	2.4	7.22	N/A	0.6	7.16	
TEL-5-24	1.42	2.9	8.85	N/A	0.9	10.11	
TEL-6-24	1.7	3.4	10.46	N/A	0.9	13.32	
LOW TEMP 30" WIDE DOORS							
TEL-2-30	0.57	1.5	4.41	N/A	0.6	5.52	
TEL-3-30	0.85	1.9	6.45	N/A	0.6	7.16	
TEL-4-30	1.13	2.4	8.53	N/A	0.9	10.11	
TEL-5-30	1.42	2.9	10.47	N/A	0.9	13.32	

SHIPPING WEIGHTS

MODEL	SHIP WT. LB/KG
MEDIUM TEMP 24" WIDE DOORS	
TEM-3-24	1325/602
TEM-4-24	1520/691
TEM-5-24	1720/782
TEM-6-24	2140/973
MEDIUM TEMP 30" WIDE DOORS	
TEM-2-30	755/343
TEM-3-30	1435/652
TEM-4-30	1670/759
TEM-5-30	2000/909
LOW TEMP 24" WIDE DOORS	
TEL-3-24	1245/566
TEL-4-24	1300/591
TEL-5-24	1720/782
TEL-6-24	2140/973
LOW TEMP 30" WIDE DOORS	
TEL-2-30	1085/493
TEL-3-30	1325/602
TEL-4-30	1915/870
TEL-5-30	1955/889

LISTINGS



ANSI/NSF 7

HOOKUP

Hardwire, remote refrigeration.

MODULES REQUIRED FOR 24" WIDE DOOR LINEUPS & BTU PERFORMANCE DATA

NO. OF DOORS	MODULES REQUIRED				TOTAL OVERALL LENGTH WITH ONE PAIR OF 2" ENDS	+20°F SUCTION MIN. BTUs (75°F STORE, 55% RH, +35°F AVERAGE PRODUCT TEMP.)	-11°F SUCTION MIN. BTUs (75°F STORE, 55% RH, -3°F AVERAGE PRODUCT TEMP.)	-18°F SUCTION MIN. BTUs (75°F STORE, 55% RH, -12°F AVERAGE PRODUCT TEMP.)
	3 DOOR	4 DOOR	5 DOOR	6 DOOR				
3	1				78 ¹ / ₄ "	3750	4750	5125
4		1			102"	4600	6150	6550
5			1		125 ³ / ₄ "	5750	7625	8300
6				1	149 ¹ / ₂ "	6900	9150	9960
7	1	1			176 ¹ / ₄ "	8050	10,675	11,620
8		2			200"	9200	12,200	13,280
9		1	1		223 ³ / ₄ "	10,350	13,725	14,940
10			2		247 ¹ / ₂ "	11,500	15,250	16,600
11			1	1	271 ¹ / ₄ "	12,650	16,775	18,260
12				2	295"	13,800	18,300	19,920
13		2	1		321 ³ / ₄ "	14,950	19,825	21,580
14		2		1	345 ¹ / ₂ "	16,100	21,350	23,240
15			3		369 ¹ / ₄ "	17,250	22,875	24,900
16		4			396"	18,400	24,400	26,560
17			1	2	416 ³ / ₄ "	19,550	25,925	28,220
18				3	440 ¹ / ₂ "	20,700	27,450	29,880
19		1	3		467 ¹ / ₄ "	21,850	28,975	31,540
20			4		491"	23,000	30,500	33,200
21	1			3	514 ³ / ₄ "	24,150	32,025	34,860
22		1		3	538 ¹ / ₂ "	25,300	33,550	36,520
23			1	3	562 ¹ / ₄ "	26,450	35,075	38,180
24				4	586"	27,600	36,600	39,840
25			5		612 ³ / ₄ "	28,750	38,125	41,500

MODULES REQUIRED FOR 30" WIDE DOOR LINEUPS & BTU PERFORMANCE DATA

NO. OF DOORS	MODULES REQUIRED				TOTAL OVERALL LENGTH WITH ONE PAIR OF 2" ENDS	+20°F SUCTION MIN. BTUs (75°F STORE, 55% RH, +35°F AVERAGE PRODUCT TEMP.)	-11°F SUCTION MIN. BTUs (75°F STORE, 55% RH, -3°F AVERAGE PRODUCT TEMP.)	-18°F SUCTION MIN. BTUs (75°F STORE, 55% RH, -12°F AVERAGE PRODUCT TEMP.)
	2 DOOR	3 DOOR	4 DOOR	5 DOOR				
2	1				67 ¹ / ₂ "	2800	3300	3550
3		1			98 ¹ / ₂ "	3750	4750	5125
4			1		128 ¹ / ₂ "	4600	6150	6550
5				1	159"	5750	7625	8300
6		2			193"	6900	9150	9960
7	1			1	222 ¹ / ₂ "	8050	10,675	11,620
8		1		1	253 ¹ / ₂ "	9200	12,200	13,280
9			1	1	283 ¹ / ₂ "	10,350	13,725	14,940
10				2	314"	11,500	15,250	16,600
11		2		1	348"	12,650	16,775	18,260
12	1			2	377 ¹ / ₂ "	13,800	18,300	19,920
13		1		2	408 ¹ / ₂ "	14,950	19,825	21,580
14			1	2	438 ¹ / ₂ "	16,100	21,350	23,240
15				3	469"	17,250	22,875	24,900
16		2		2	503"	18,400	24,400	26,560
17	1			3	532 ¹ / ₂ "	19,550	25,925	28,220
18		1		3	563 ¹ / ₂ "	20,700	27,450	29,880
19			1	3	593 ¹ / ₂ "	21,850	28,975	31,540
20				4	624"	23,000	30,500	33,200
21		2		3	658"	24,150	32,025	34,860
22	1			4	687 ¹ / ₂ "	25,300	33,550	36,520
23		1		4	718 ¹ / ₂ "	26,450	35,075	38,180
24			1	4	748 ¹ / ₂ "	27,600	36,600	39,840
25				5	779"	28,750	38,125	41,500

TECHNICAL DRAWINGS

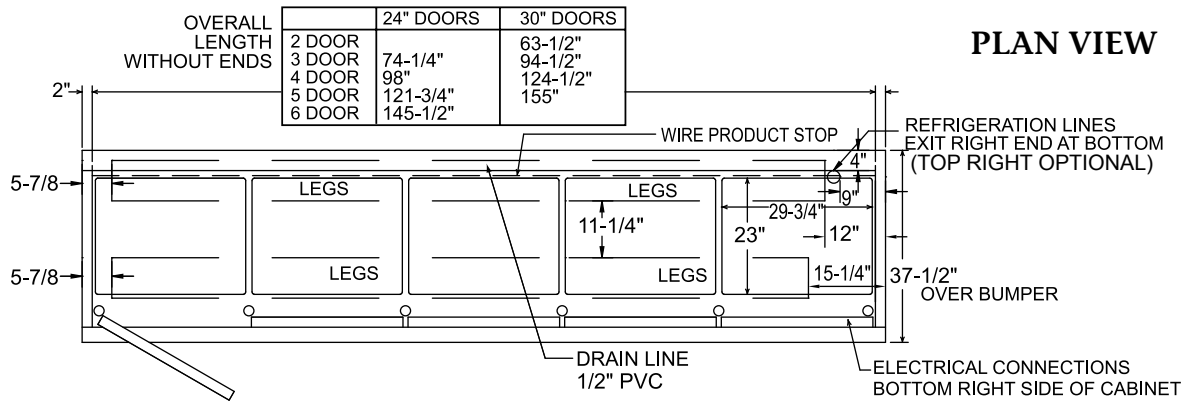

PLAN VIEW

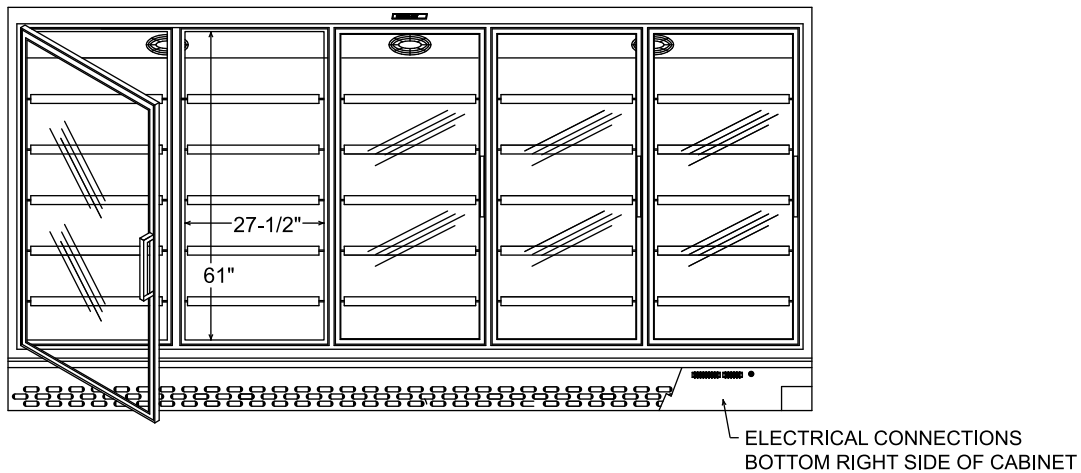

ELEVATION VIEW

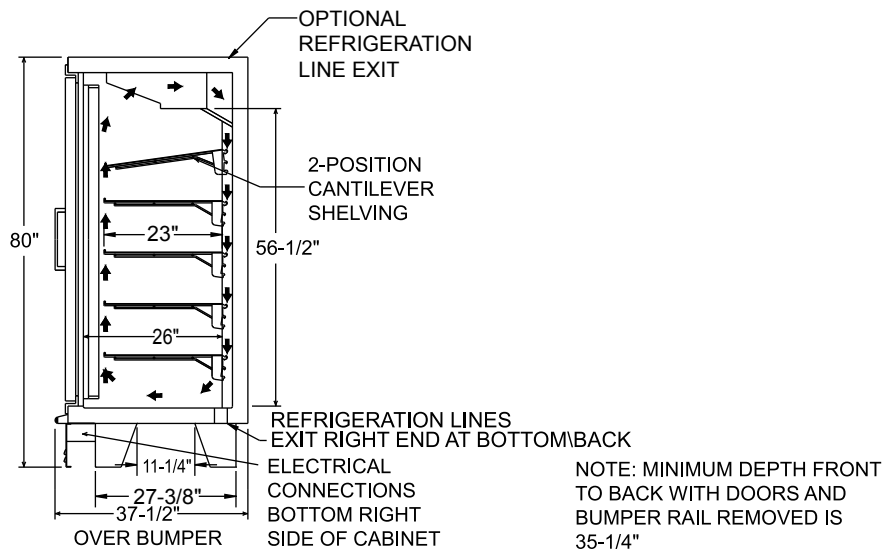

SIDE VIEW



TEM/TEL SERIES

ENDLESS REMOTE GLASS DOOR MERCHANDISERS
WITH TOP MOUNTED COIL

REQUIRED CONDENSING UNITS

Use this chart to determine the correct condensing unit for your endless lineup.

Unless already indicated, add suffix "B" for one phase or "C" for three phase model.

NO. OF DOORS	+35°F AVERAGE PRODUCT TEMP. +20°F SUCTION 75°F AIR CONDITIONED STORE 55% RELATIVE HUMIDITY			-3°F AVERAGE PRODUCT TEMP. -11°F SUCTION 75°F AIR CONDITIONED STORE 55% RELATIVE HUMIDITY			-12°F AVERAGE PRODUCT TEMP. -18°F SUCTION 75°F AIR CONDITIONED STORE 55% RELATIVE HUMIDITY		
	COND. UNIT REQUIRED FOR AIR TEMP. ENTERING CONDENSER*			COND. UNIT REQUIRED FOR AIR TEMP. ENTERING CONDENSER*			COND. UNIT REQUIRED FOR AIR TEMP. ENTERING CONDENSER*		
	90°F	100°F	110°F	90°F	100°F	110°F	90°F	100°F	110°F
2	MHHZ0071B	MHHZ0071B	MHHZ0071B	MHLZ0071	MHLZ0071	MHLZ0071	MHLZ0091	MHLZ0091	MHLZ0091
3	MHHZ0071B	MHHZ0071B	MHHZ0071B	MHLZ0071	MHLZ0091	MHLZ0091	MHLZ0091	MHLZ0121	MHLZ0121
4	MHHZ0071B	MHHX0081B	MHHX0081B	MHLZ0091	MHLZ0091	MHLZ0121	MHLZ0121	MHLZ0121	MHLZ0121
5	MHHZ0081B	MHHZ0081B	MHHZ0111	MHLZ0091	MHLZ0121	MHLZ0121	MHLZ0121	MSLZ0151	MSLZ0181
6	MHHZ0111	MHHZ0111	MHHZ0111	MHLZ0121	MHLZ0121	MSLZ0151	MSLZ0151	MSLZ0181	MSLZ0221
7	MHHZ0111	MHHZ0111	MHHZ0171	MHLZ0121	MSLZ0151	MSLZ0181	MSLZ0181	MSLZ0221	MSLZ0221
8	MHHZ0171	MHHZ0171	MHHZ0171	MSLZ0151	MSLZ0181	MSLZ0181	MSLZ0221	MSLZ0221	MSLZ0221
9	MHHZ0171	MHHZ0171	MHHZ0191	MSLZ0181	MSLZ0181	MSLZ0221	MSLZ0221	MSLZ0221	BSLZ0750
10	MHHZ0171	MHHZ0191	MHHZ0191	MSLZ0181	MSLZ0221	MSLZ0221	MSLZ0221	BSLZ0750	BSLZ0750
11	MHHZ0191	MHHZ0191	MHHZ0221	MSLZ0221	MSLZ0221	MSLZ0221	BSLZ0750	BSLZ0750	BSLZ0750
12	MHHZ0191	MHHZ0221	MHHZ0221	MSLZ0221	MSLZ0221	BSLZ0750	BSLZ0750	BSLZ0750	BSLZ1000
13	MHHZ0191	MHHZ0221	MHHZ0251	MSLZ0221	BSLZ0750	BSLZ0750	BSLZ0750	BSLZ1000	BCLZ0750
14	MHHZ0221	MHHZ0251	MHHZ0251	BSLZ0750	BSLZ0750	BSLZ0750	BSLZ1000	BSLZ1000	BSLZ1500
15	MHHZ0251	MHHZ0251	MHHZ0301	BSLZ0750	BSLZ0750	BSLZ1000	BSLZ1000	BSLZ1000	BSLZ1500
16	MHHZ0251	MHHZ0251	MHHZ0301	BSLZ0750	BSLZ1000	BSLZ1000	BSLZ1000	BSLZ1500	BSLZ1500
17	MHHZ0251	MHHZ0301	MHHZ0331	BSLZ0750	BSLZ1000	BSLZ1000	BSLZ1500	BSLZ1500	BSLZ1500
18	MHHZ0301	MHHZ0301	MHHZ0331	BSLZ1000	BSLZ1000	BSLZ1500	BSLZ1500	BSLZ1500	BSLZ1500
19	MHHZ0301	MHHZ0331	MHHZ0331	BSLZ1000	BSLZ1000	BSLZ1500	BSLZ1500	BSLZ1500	BSLZ1500
20	MHHZ0301	MHHZ0331	MHHZ0431	BSLZ1000	BSLZ1500	BSLZ1500	BSLZ1500	BSLZ1500	BCLZ1500
21	MHHZ0331	MHHZ0331	MHHZ0431	BSLZ1000	BSLZ1500	BSLZ1500	BSLZ1500	BSLZ1500	BCLZ1500
22	MHHZ0331	MHHZ0431	MHHZ0431	BSLZ1500	BSLZ1500	BSLZ1500	BSLZ1500	BCLZ1500	BCLZ1500
23	MHHZ0331	MHHZ0431	MHHZ0431	BSLZ1500	BSLZ1500	BSLZ1500	BSLZ1500	BCLZ1500	BCLZ1500
24	MHHZ0431	MHHZ0431	MHHZ0431	BSLZ1500	BSLZ1500	BSLZ1500	BCLZ1500	BCLZ1500	BCLZ1500
25	MHHZ0431	MHHX0441	MHHZ0501	BSLZ1500	BSLZ1500	BSLZ1500	BCLZ1500	BCLZ1500	BCLZ1500

*Condensing unit and line size based on 100' line run.

See the Master-Bilt Condensing Unit & Refrigeration Systems I/O Manual for other conditions.

For other than high capacity condensing units, consult factory.

BID SPECIFICATIONS

Item no. TEM-_____ and/or TEL-_____.

Provide _____ () Endless Remote Glass Door Merchandisers - Top Mounted model no. TEM-_____ and/or TEL-_____.

Merchandiser to be constructed of white painted galvanized steel with 2" foamed-in-place "zero ODP" urethane insulation. Merchandiser may be used as a stand-alone unit or combined in a modular endless design.

Standard TEM model vertical lighting features T-12 high output bulbs while TEL models are equipped with T-10 bulbs.

Merchandiser will contain five white cantilever epoxy-coated welded wire shelves with price tag molding per door. In addition,

a product stop feature will prevent product from falling behind shelves. Other standard features to include:

- Heavy-duty rub rail and kick plate
- Pre-wired cabinet-to-cabinet electrical terminal block connectors
- Standard joining kits when linking together multi-door modules
- Pre-piped drain in bottom of each section with removable plug for cleaning

Glass doors will be supplied with self-closing door hinge and provision for easy adjustment of torsion and leveling. Merchandiser supplied with either 24" or 30" wide glass doors. Door and frame

provided in standard black finish with optional colors available.

The refrigeration system will be remote and will contain a full-length heavy-duty copper tube evaporator coil and pre-mounted expansion valve. There will also be a choice of electric or hot gas defrost. Additionally, merchandiser will be supplied with an oversized raceway for ease of refrigeration piping. All models will use R-404A refrigerant.

Temperature ranges will be:

- TEM models: 34° to 41°F (1° to 5°C)
- TEL models: 0° to -15°F (18° to -26°C)

Merchandiser to be provided with two year limited parts and 90 day labor warranty.

NOTE: Cabinet designed for optimum performance in air-conditioned area at 75°F ambient and 55% relative humidity. All specifications subject to change without notice.

MBMASTER-BILT
Refrigeration Solutions

908 Highway 15 North • New Albany, MS 38652
PHONE: 800-647-1284 or 662-534-9061 • FAX: 800-232-3966 or 662-534-6049 • www.master-bilt.com

Standex
Food Service Equipment Group