

PHOENIX TANDOORI OVEN

GAS AND ELECTRIC MODELS

SNB



MADE IN THE
U.S.A.

NSF-4 & ETL APPROVED



CONFORMS TO ANSI Z 83.11
CONFORMS TO ANSI/NSF 4
CERTIFIED TO CSA 1.8
CONFORMS TO NSF/ANSI 4-E
STANDARD UL197 NINETH EDITION

- **Design and Layout Services**
- **Equipment**
- **Delivery/Shipping**
- **Installation**
- **Buy – Sell – Trade**
- **Repair Service**

WORLDS FIRST ELECTRIC TANDOORI OVEN

Introduction

N.S.B. would like to thank you for choosing the Phoenix Tandoori Oven. This product is designed with safety and reliability for years to come, the oven is made for commercial use only and to be used in your eating establishment.

The Phoenix is the latest, newest, and most economical oven in the industry, must be used by professionals who are familiar with Tandoori Cooking. The most GAS and ELECTRIC efficient and money savings units.

The 16" opening is one of the largest on the market. This oven is one of the safest ovens to be made in the states, the tilt in the design is to prevent burning of hands, arms and face.

WARNING:

Improper installation, adjustment, alteration, service or maintenance can cause property damage, injury or death. Read the installation, operating and maintenance instructions thoroughly before installing or servicing this equipment.

- Must be installed under a Vent Hood
- Keep all combustible products away from Tandoori
- Must be installed by professional qualified technician
- Please keep this manual available at all times near the Tandoori for all future reference.
- Tandoori is Gas or Electric, no Charcoal use
- Keep at least 6" away from any other equipment
- This Tandoori becomes very hot on top of ceramic

PRE INSTALLATION

- This equipment is made with quality materials; proper installation must conform to all local codes and with National Fuel GAS Code, ANSI Z223.1-1988 or its latest edition. Installation of this gas fired equipment must be performed by a licensed plumber.
- The appliance and it's individual shutoff valve must be disconnected from the gas supply piping system during and pressure testing of that system at test pressures in excess of 1/2 psi.
- The appliance must be isolated from the gas supply piping system by closing its individual manual shutoff valve during any pressure testing of the gas supply piping system at test pressures equal to or less than 1/2 psi.
- This appliance requires clearances from Combustibles and Non/Combustible materials. 6" Inches for Combustibles and Non/Combustibles.
- Ventilation Hood must be installed above the unit according to all applicable codes by your Local and state health & fire regulations.
- Do not install closer than 6" to the sides and 6" to the back wall.

UNPACKING AND INSTALLING THE TANDOORI

- Uncrate the unit very carefully, do not use hammer or heavy tools to uncrate the unit, always use outward prying.
- Make sure the unit is in upright position before you start to uncrate.
- Unit is on Casters. Roll out to a spot where unit is to be easily installed.
- Do not use a jack; all movement must be done by hand.
- Unit may need to be leveled.
- Gas connection must be the same size of the Tandoori NPT 3/4 inlets.
- A shut off valve must be installed on the gas service line ahead of the unit in the event of an emergency, or repairs.
- A quick disconnect hose for Gas unit is needed. Electrical connection must be done according to manual. A shut-off panel must be installed nearby the oven in case of emergency and repairs. Safety chain to be installed on both units.

REGULATING (GAS ONLY)

This Tandoori is made with a shut off valve, must be disconnected from the gas line for pressure testing.

Pressure regulator must be installed on the gas system pipe line and isolated from other equipment for the shut off valve and pressure testing.

A manometer must be used to check pressure manifold. The unit is suited for Natural or propane Gas. Regulators can be adjusted on site.

All connections must be sealed with joint compound for both Natural and Propane gas. A special mixed soapy solution must be used to test the unit before lighting the pilot. Do not for any reason use open flame fire to test for leaks.

A flex hose must be used to connect the Tandoori unit, also a quick disconnect hose can be used; a professional installer must use heavy duty commercial connector at least 3/4 NPT. All quick disconnect hose must comply with all the standard devices and use with a gas fuel.

A restrained must be connected to the wall and the unit for safety.

FOR YOUR SAFETY

Do not store or use gasoline or other flammable vapors or liquids in the vicinity of this or any other appliance.

IMPORTANT

Installation shall be made with a connector that complies with the Standard for Connectors for Movable Gas Appliances, ANSI Z21.69-CSA6.16, and a quick disconnect device that complies with the Standard for Quick Disconnect Devices for the Use with Gas Fuel, ANSI Z21.41-CSA 6.9".

Features and Specifications

GAS OVEN MODEL (NO. 6153-G)

Standard Features

- Gas Input Rating 45,000 BTU/HR in Natural Gas 4.5"-W.C.
- Orifice Size 1/8 Natural, .1250 Metric
- Gas Input Rating 45,000 BTU/HR in Propane Gas 11"-W.C.
- Orifice Size 71 Propane, .0260 Metric
- Dimensions, 34"W X 35"D X 38" H
- All Stainless Steel Exterior Construction
- Ceramic Heats up to 1200 Degrees F
- Unit comes with 6" Casters
- Cast Iron Burner Round for Even Heat
- 3/4 NPT Gas Connection
- Automatic Shut off Pilot
- Temperature Control On/Off & Igniter Starter
- Shipping Weight Crated 350 lbs

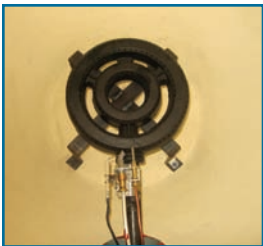

ELECTRIC OVEN MODEL (NO. 6153-E)

Standard Features

- All Stainless Steel Exterior Construction
- Ceramic Insert heat up to 1200 Degrees F.
- Unit comes with 6" casters
- Steel Cover over Burner 15" to protect element
- Electric Element 7800 Watts, 40 Amp Contactor
- ON and Off Switch & High Limit Switch
- Solid State Thermostat Temperature Control
- Available in 240/480 Electric 1 or 3 Phase
- Shipping Weight Crated 325 lbs

Model 6153-E	Electrical Date	1-Phase	3-Phase	Watts	Total KW
Voltage	240-60 HZ	36 Amps	25 Amps	7800	7.8 kw
Voltage	480-60 HZ	20 Amps	15 Amps	7800	7.8 kw

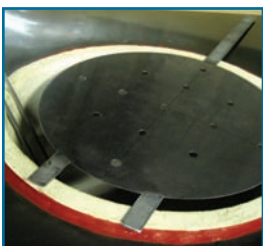

N.S.B PHOENIX TANDOORI OVEN

Manufacturer's Limited Labor & Parts Warranty

N.S.B. Food Service Equipment and Supplies of the State of Virginia known as (Seller) Warranty. the PHOENIX TANDOORI OVEN, against defects in material and workmanship under normal use and service, for 12 months from the date of Purchase. N.S.B warrants to the original purchaser only. The labor warranty is 90 days from the date of purchase. The parts warranty is one (1) year from date of purchase. N.S.B will bear the cost of labor in normal charges performed during regular business hours and not subject to overtime costs. N.S.B is not responsible for warranty if equipment been tempered with, modified in any manner, or substituted with parts not authorized by the manufacturer, equipment that is damaged by the misuse or improper installation or alteration. Warranties do not extend to any losses or, accident, abuse, neglect, normal wear and tear, Failure by buyer to notify the seller within the applicable time period shall be deemed an absolute and unconditional waiver of buyer claim for such nonconformity.

Seller assumes no responsibility for any loss, damage or injury to any person or property arising out of, connected with, or resulting from the use of the equipment, either alone or in combination with other products or components. Seller has the right to inspect and or make final decision on a warranty that may be questionable. This warranty is being expressed in lieu of all other warranties, expressed or implied, and of all other obligations or liabilities on our part, and we neither assume nor authorize anyone to assume for us any other liability in connection with the PHOENIX TANDOORI OVEN.

All claims for labor or parts must be made through the local service agency. The defective parts, for which labor reimbursement is claimed, together with the service invoice, must be returned to the manufacturer to be eligible for labor and parts warrant coverage. All parts must be approved by N.S.B and all claims shall include the product model & serial numbers and the date of service.

Note: A 25% restocking charge will be deducted for returned items, all equipment or parts returned for credit must have prior approval and authorization been issued by N.S.B the equipment must be returned in the original packaging.

Warranties stated above are the only warranties made in connection with the sale and distribution of the PHOENIX TANDOORI OVEN, and distribution of the product. Any and all other statutory or implied warranties applicable to the product, including, without limitation, and implied warranties of merchant ability and fitness for use are expressly disclaimed.

GO GREEN - STAY CLEAN

TO WARM THE OVEN FOR MODEL 6153-E

- Turn the ON and OFF switch to ON
- Turn the Thermostat to Desired Temperature
- Pilot Light Should be ON
- Cover Top of Oven with S. S. Cover
- Oven should be warm to bake within 35/45 minutes
- Keep Hands, Face, and Arms from the opening of the oven
- To Shut the oven OFF turn the Thermostat to OFF and turn the ON and OFF Switch to OFF, Indicator light will shut off.

TO WARM THE OVEN FOR MODEL 6153-G

- Once the Pilot flame is lit, turn the gas valve to ON
- Put the S. S. Cover on Top for 20/25 Minutes
- Remove cover oven if ready for operation
- Medium Temperature should keep oven temp around
- 350/450 Degrees (set according to your cooking speed)
- Keep Hands, Face, and Arms from the opening of the oven
- To Shut oven OFF just turn the Gas Valve to OFF position

CLEANING AND MAINTENANCE

- All units are made with an 18 gauge stainless steel which is easy to clean.
- This unit will work more efficient with proper cleaning, and will have longer life with simple maintenance.
- Do not use any abrasives, cleansers, or harmful powders, just scrape and remove all items stuck to unit.
- Remove or Vacuum any debris from bottom of oven, in the morning when (Cold).
- Clean inside Ceramic with green pad only.
- Replacing the burner should be done by a trained professional.



OVEN DIMENSIONS:

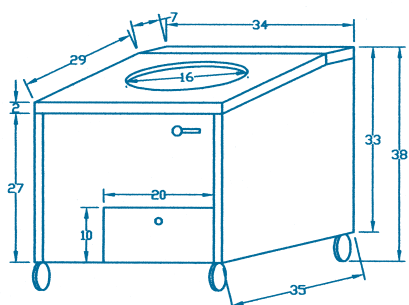
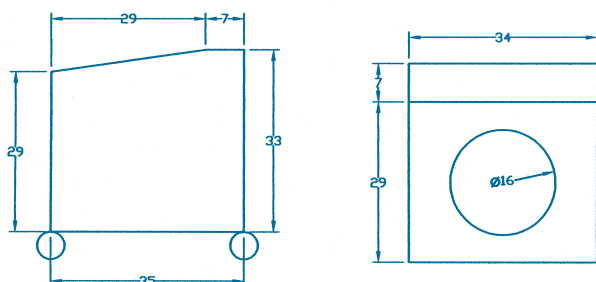

CONFORMS TO ANSI Z 83.11
CONFORMS TO ANSI/NSF 4
CERTIFIED TO CSA 1.8
CONFORMS TO NSF/ANSI 4-E
STANDARD UL197 NINETH EDITION

N.S.B Food Service Equipment and Supplies

3702 Donna Lane Annandale, VA 22003-1807

Sales, Service and Parts. Bill Barbari

Phone: 703-618-6300 • Fax: 703-941-6677

Email: nabilbarbari@yahoo.com

Web-page: www.nsbequipment.com

Tech Support and Repairs. Solaiman Farbod

Phone: 240-899-0312 • Email: sfarbod@yahoo.com