

CENTURY SYSTEM POWER PAKS – WATER-COOLED

Perlick Features

- 1/3, 1/2 and 3/4 HP 115 volt models.
- 134a, constant pressure expansion valve and condensing unit with service valves.
- Adjustable electronic temperature control with digital readout.
- High efficiency, compact heat exchanger provides more efficiency for longer beer runs.

Horsepower	Length of run
1/3	150 feet
1/2	300 feet
3/4	500 feet

Based on 75 degree ambient temperature.

- Top mounted closed-coupled pump and 1/3 HP ball bearing motor assembly for easy service.
- Factory pre-mixed glycol guarantees performance.
- Optional leg kit for free standing off the floor installation.
- Optional multiple pump kits.

MODEL NOS.

- 4404W Series
- 4410W Series
- 4414W Series

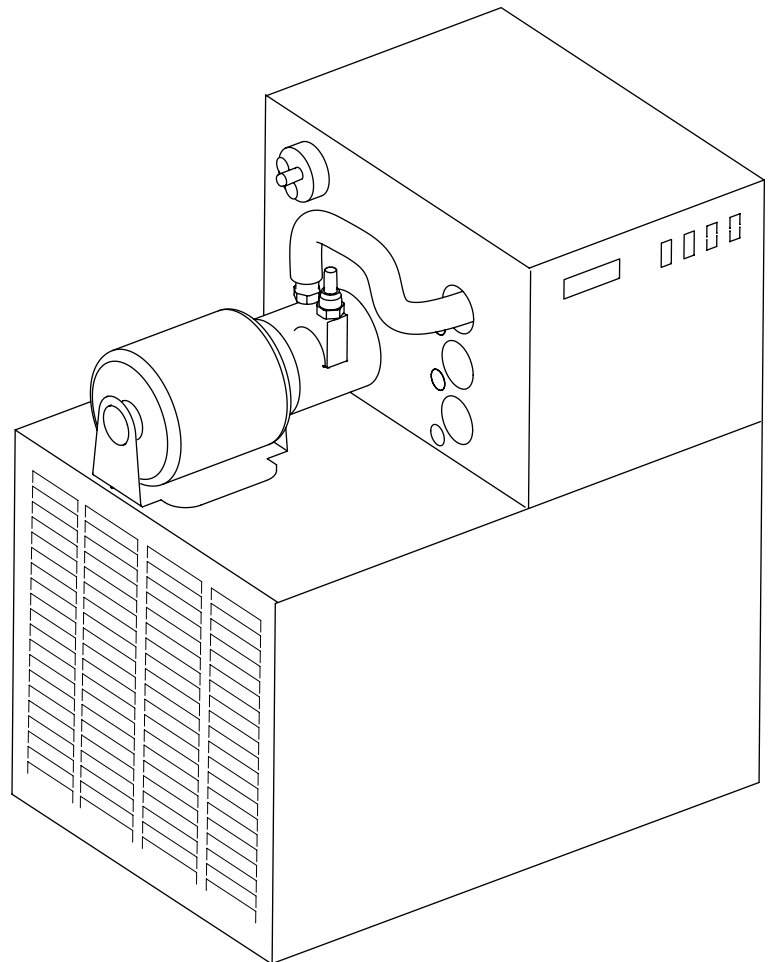

Sizes and Specifications Century System Power Paks — Water-Cooled

Job _____
 Area _____
 Item No. _____
 Model No. _____

MODEL NOS.		4404W	4410W	4414W
DIMENSIONS:	Length "A"	24 1/4" (616)	24 1/4" (616)	26 3/4" (679)
	Width "B"	17 1/4" (438)	17 1/4" (438)	20 1/4" (519)
	Height "C"	25 1/2" (648)	25 1/2" (648)	31" (782)
A minimum of six inches of clearance should be allowed around the entire unit for proper performance. Additional clearance should be considered for above the unit and in front of the unit for serviceability.				
ELECTRICAL	Voltage	120 V	120 V	120 V
	Freq.	60 Hz	60 Hz	60 Hz
	Phase	1Ø	1Ø	1Ø
SINGLE PUMP	RLA	9.7	12.7	13.4
	MCA	17.8	19.9	20.4
DUAL PUMPS	RLA	N/A	15.5	16.2
	MCA	N/A	22.7	23.2
TRIPLE PUMP	RLA	N/A	N/A	N/A
	MCA	N/A	N/A	N/A
COMPRESSOR:		1/3 HP	1/2 HP	3/4 HP
EVAPORATOR RATING @ 20°F (BTUH)		3420	4080	6870
HEAT REJECTION (Max)		2050	2450	4122
REFRIGERANT		R-134a	R-134a	R-134a
SHIPPING WEIGHT LBS (kg)		141 (64)	143 (65)	205 (93)
MAXIMUM FOOTAGE IN SYSTEM (Based on 75 degree ambient)		150 ft.	300 ft.	500 ft.
CABINET		Stainless Steel		
CIRCULATING PUMP		100 GPH / 150 PSIG		
RESERVOIR CAPACITY		1.75 gal	1.75 gal	1.75 gal
REFRIGERATION:		Constant Pressure Expansion Valve, Condensing Unit with Service Valves		
REFRIGERANT CHARGE (grams)		14.5 oz/410 g	14.5 oz/410 g	22.0 oz/623 g
GLYCOL CONCENTRATION		33%	33%	33%
PLUMBING REQUIREMENTS				
INLET & OUTLET		All employ 1/2" O.D. Quick Connect Fittings		
FLOW RATE (gpm) @ 75°F		0.5	0.6	0.9
PRESSURE DROP (psig)		0.1	0.2	0.4
MAX SUPPLY PRESSURE		All Models: Incoming Water Pressure not to exceed 150 psig.		
OPTIONAL ACCESSORIES	4430	115V pump kit for 4410 power paks (Field Installed)	61790	Dual tier rack
	4431	115V pump kit for 4414 power pak (Field Installed)	61791+1	Triple tier rack
	4435	BLM receptacle	61792+2	Quad tier rack
	4408SS	Wall bracket for 4404 & 4410 only	C22296A-20	Cord kit for 120V single pump power paks only
	57782	Set of four adjustable legs	C21499BSS	Stainless steel table stand
	54838	Water hammer arrestor (add if incoming water is under 65°F)		

*Note: Allow a minimum of six inches of clearance on the louvered ends of the cabinet for proper air flow. Allow accessibility room on top and front of cabinet for serviceability. Above specifications are subject to change without prior approval.

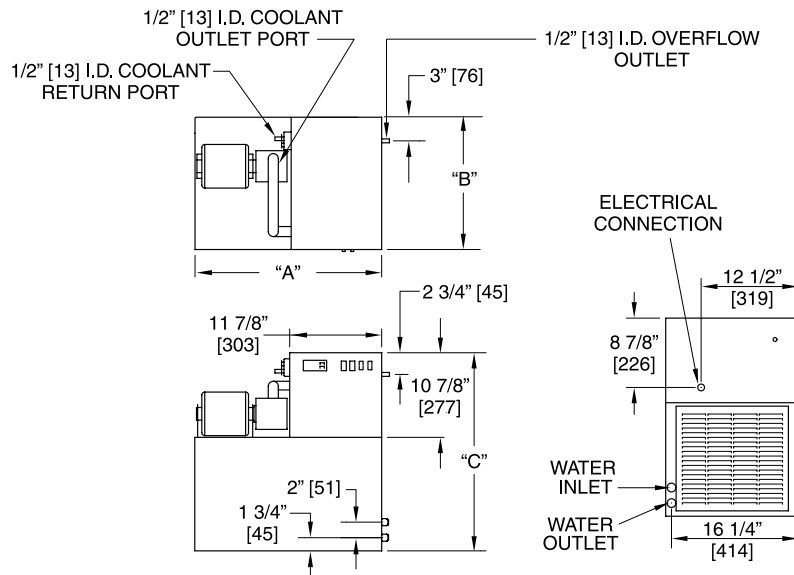

8300 West Good Hope Road • Milwaukee, WI 53223 • Phone 414-353-7060 • Fax 414-353-7069
 Toll Free 800-558-5592 • E-Mail: Perlick@Perlick.com • www.Perlick.com