

CUSTOM REMOTE CABINETS

Perlick Features

- Available in 2, 3 or 4 door models.
- Self-closing field reversible doors with locks.
- Approved for ANSI/NSF #7 open food.
- Two inch foamed-in-place insulation provides greater energy efficiency and structural strength.
- Two inch thermal breaks and mullion heaters combine to resist condensation build up around the door openings.
- Low-E glass doors improve insulation and resist condensation on the glass.
- Compact fluorescent light above each door fully illuminates interior.
- Factory installed expansion valve. Choice of either R22, R404A or R134a.
- Heavy-duty, reinforced base will not bend or sag.
- Heavy-duty polyethylene door sill.
- Stainless steel exterior.
- Heavy-duty stainless steel hinges.
- Epoxy coated evaporator coil.
- Optional draft beer dispensing system available with a variety of dispensing head styles.
- Vinyl coated shelves.
- Stainless steel top included.
- Multiple door finish options.

MODEL NOS.

- BR48
- BR72
- BR96

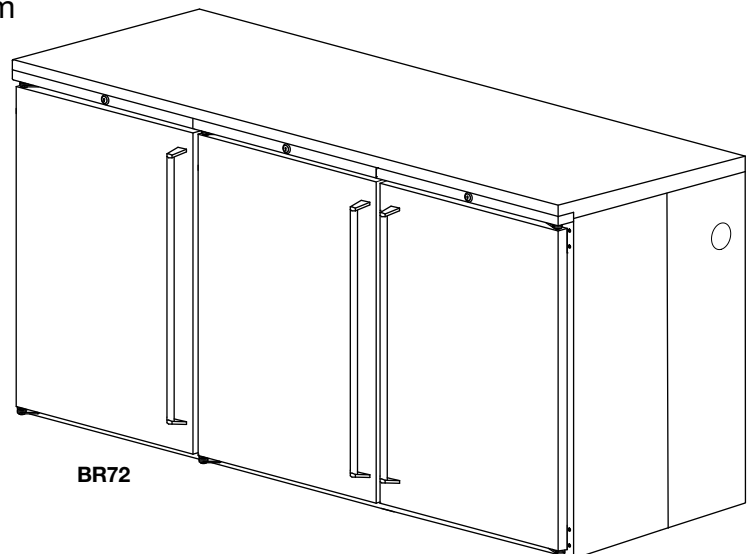

BR72



Sizes and Specifications Custom Remote Cabinets

Job _____
 Area _____
 Item No. _____
 Model No. _____

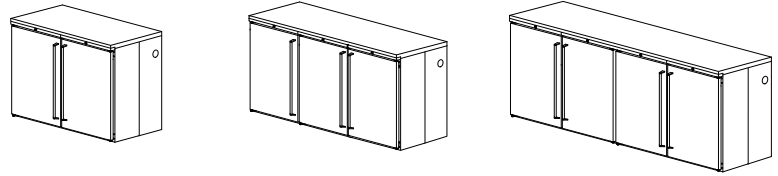
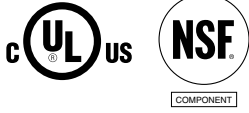

MODEL NOS.	BR48	BR72	BR96	
NUMBER OF DOORS	2 Door	3 Door	4 Door	
CABINET DIMENSIONS	Length - Inches (mm)	48" (1219)	72" (1829)	96" (2439)
	Depth - Inches (mm)	24 ³ / ₄ " (629)	24 ³ / ₄ " (629)	24 ³ / ₄ " (629)
	Height - Inches (mm)	34 ¹ / ₂ " (876)	34 ¹ / ₂ " (876)	34 ¹ / ₂ " (876)
CASE CAPACITY (based on 12 oz. Long Neck bottle)	15	24	32	
AMPS	1.6	2.0	2.5	
SHIP WT. Lbs. (kg.)	310 (140)	400 (181)	540 (245)	
INTERIOR	Door sill: High strength polyethylene. Door pan and ceiling: High strength polystyrene. Floor pan: Stainless steel. Includes pilasters, (2) vinyl coated shelves and floor rack per door, and interior lights.			
EXTERIOR	Front, back, top and sides, stainless steel. Bottom galvanized steel. See optional accessories for door finishes.			
DOOR HINGING	Stainless steel hinges with standard location as illustrated. For special hinging Specify hinge locations starting left to right. Field reversible.			
DOOR HARDWARE	Door handles: Choice of full length stainless steel, classic 6" black vinyl wrapped pull or top mounted stainless steel pull tab. Lock finish: chrome.			
REFRIGERATION	Aluminum fin and copper tube evaporator, epoxy coated coil. Factory installed expansion valve. Choice of R22, R404A or R134a. Copper tube connection stubbed out left side of evaporator assembly. Suction line accepts 3/8" O.D. copper tubing. Liquid line accepts 1/4" O.D. copper tubing.			
ELECTRICAL	115V, 60Hz., 1 phase AC. Contact Perlick for other voltage/frequency requirements.			
PLUMBING	Independent floor drain or condensate evap. pan is req'd. Optional 2 ¹ / ₈ " I.D. floor access kit-left rear corner.			
INSULATION	Foamed-in-place polyurethane, 2" walls, 1 ¹ / ₂ " top.			
OPTIONAL ACCESSORIES & MODIFICATIONS	<ul style="list-style-type: none"> • Leg set • Tapping kit • Laminated top • Laminated ends • Brass hardware (classic and full length only) • Caster sets • Base plates • Floor access kit <p>Door finishes Black vinyl coated Stainless steel Customers choice of laminate Painted in color of choice Prepared for field lamination Glass door with black vinyl coated frame Glass door with stainless steel frame Glass door with laminated frame</p>			

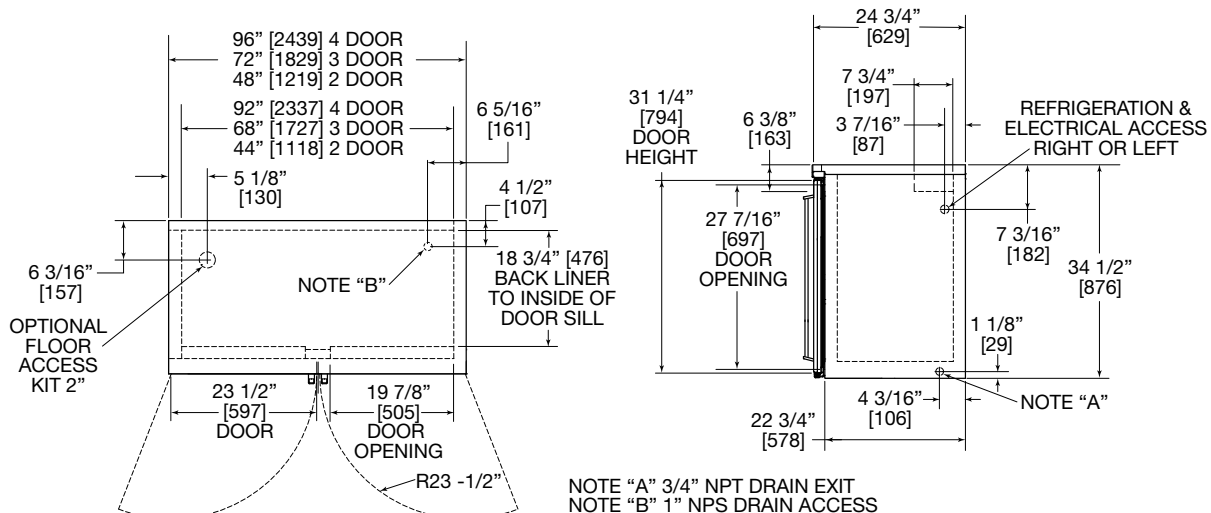

8300 West Good Hope Road • Milwaukee, WI 53223 • Phone 414-353-7060 • Fax 414-353-7069
 Toll Free 800-558-5592 • E-Mail: Perlick@Perlick.com • www.Perlick.com