

# DUAL ZONE BACK BAR CABINET — SELF-CONTAINED

## Perlick Features

- Choice of three zone configurations:  
Refrigerator/white wine, refrigerator/red wine or white wine/red wine
- Front vented compressor.
- Self-closing field reversible doors with locks.
- Approved for ANSI/NSF #7 prepackaged, bottled and canned product.
- Quiet-running, high efficiency compressor.
- Two inch foamed-in-place insulation provides greater energy efficiency and structural strength.
- Two inch thermal breaks and mullion heaters combine to resist condensation build up around the door openings.
- Low-E glass doors improve insulation and resist condensation on the glass.
- Compact fluorescent light above each door fully illuminates interior.
- Heavy-duty, reinforced base will not bend or sag.
- Heavy-duty polyethylene door sill.
- Stainless steel exterior.
- Heavy-duty stainless steel hinges.
- Epoxy coated evaporator coil.
- Vinyl coated shelves.
- Optional full extension wine shelving.
- Stainless steel top included
- Multiple door finish options.

## MODEL NOS.

BSDZ60

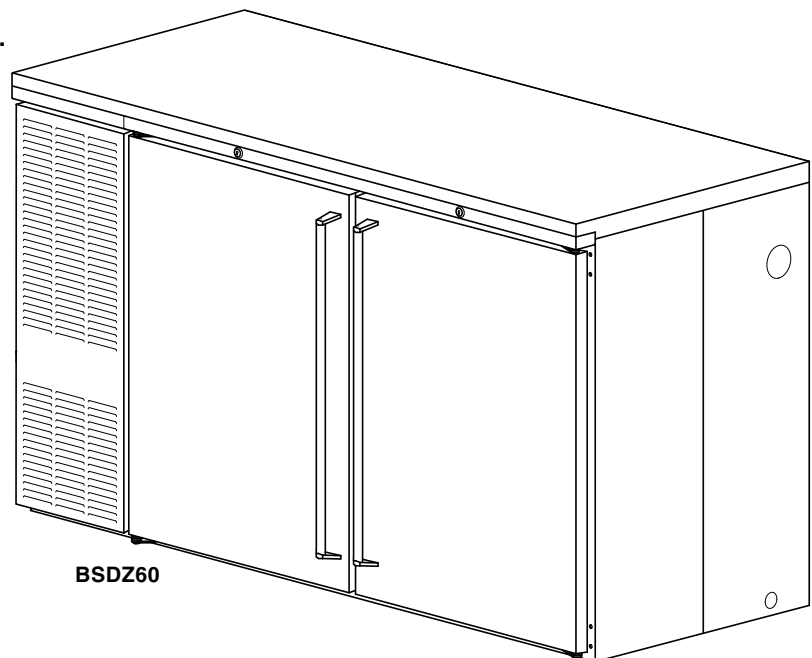

8300 West Good Hope Road • Milwaukee, WI 53223 • Phone 414-353-7060 • Fax 414-353-7069  
Toll Free 800-558-5592 • E-Mail: [Perlick@Perlick.com](mailto:Perlick@Perlick.com) • [www.Perlick.com](http://www.Perlick.com)

Form No. 022508  
Rev. 05.22.10

# Sizes and Specifications

## Dual Zone Back Bar Cabinets – Self Contained

Job \_\_\_\_\_  
 Area \_\_\_\_\_  
 Item No. \_\_\_\_\_  
 Model No. \_\_\_\_\_

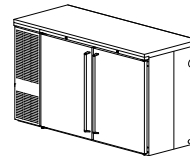

<b>MODEL NOS.</b>		<b>BS32*</b>
NUMBER OF DOORS		2
CABINET DIMENSIONS	Length - Inches (mm)	60" (1524)
	Depth - Inches (mm)	24 3/4" (629)
	Height - Inches (mm)	34 1/2" (876)
CASE CAPACITY (based on 12 oz. Long Neck bottle)		15
CASE CAPACITY (based on use of full extension wine shelves)		48 bottles (per door)
CONDENSING UNIT H.P.		1/4
RUNNING LOAD –AMPS		5.5
SHIP WT. Lbs. (kg.)		390 (177)
INTERIOR	<b>Door sill:</b> High strength polyethylene. <b>Door pan and ceiling:</b> High strength polystyrene. <b>Floor pan and Walls:</b> Stainless steel. Includes pilasters, (2) vinyl coated shelves and floor rack per door, and interior lights.	
EXTERIOR	Front, back, top and sides stainless steel. Bottom galvanized steel. See optional accessories for door & grille finishes.	
DOOR HINGING	Stainless steel hinges with standard location as illustrated. For special hinging hinge locations starting left to right. Field reversible.	
DOOR HARDWARE	<b>Door handles:</b> Choice of full length stainless steel, classic 6" black vinyl wrapped pull or top mounted stainless steel pull tab. <b>Lock finish:</b> chrome.	
REFRIGERATION	R-134a capillary tube-type. Aluminum fin and copper tube evaporator, epoxy coated coil. Adjustable temperature control for each temperature zone. Self-defrosting. Pull out condensing unit for service and cleaning. Condensing unit and evaporator left side only.	
ELECTRICAL	115V, 60Hz., 1 phase AC. Furnished with 3-prong, 6 foot NEMA5-15 PC cord. Contact Perlick for other voltage/frequency requirements.	
PLUMBING	Evaporator condensate is removed automatically. Optional floor drain with 3/4" NPT at right end or 1" NPS out bottom come plugged from factory.	
INSULATION	Foamed-in-place polyurethane, 2" walls, 1 1/2" top.	
OPTIONAL ACCESSORIES & MODIFICATIONS	<ul style="list-style-type: none"> <li>• Leg set</li> <li>• Laminated top</li> <li>• Laminated ends</li> <li>• Full extension wine shelves</li> <li>• Brass hardware (classic &amp; full length only)</li> <li>• Caster sets</li> <li>• Base plates</li> </ul>	<b>Door finishes</b> Black vinyl coated Stainless steel Customer choice of laminate Painted in color of choice Prepared for field lamination Glass door with black vinyl coated frame
		Glass door with stainless steel frame Glass door with laminated frame <b>Grille finishes</b> Black vinyl coated Stainless steel Customer choice of laminate Painted in color of choice

NOTE: This equipment is intended for the storage and display of non-potentially-hazardous bottled or canned products only.

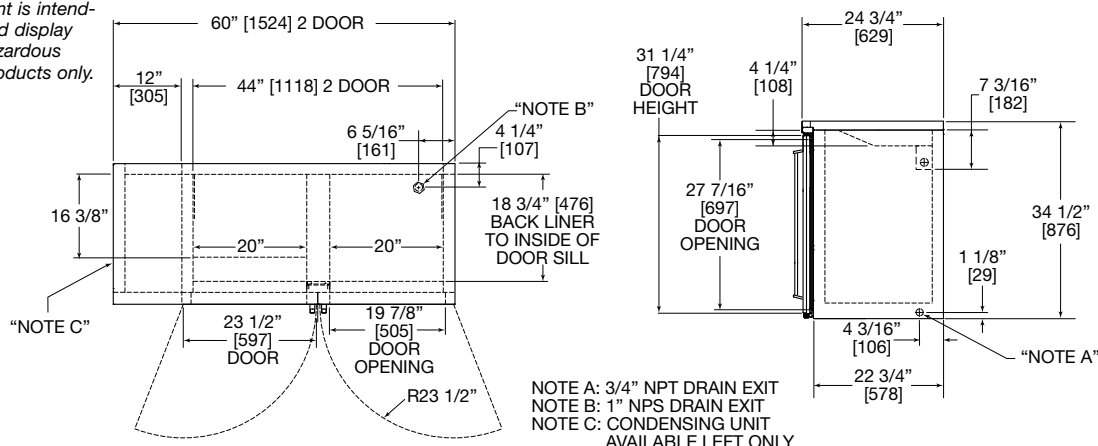

8300 West Good Hope Road • Milwaukee, WI 53223 • Phone 414-353-7060 • Fax 414-353-7069  
 Toll Free 800-558-5592 • E-Mail: Perlick@Perlick.com • www.Perlick.com