

# GLASS FROSTERS

## Perlick Features

- Two, three, four and five foot models.
- Stainless or black vinyl coated steel exteriors.
- Self contained, no plumbing required.
- Push button defrost system.
- Interior floor drain removes melting ice during defrost cycle.
- Reinforced door mullion will not bend or sag.
- Dent resistant heavy gauge doors.
- Heavy duty construction.
- Twenty four inch front to back dimension matches depth of underbar stainless steel.
- Efficient, balanced refrigeration system.
- Dependable expansion valve system.
- Quiet running, high efficiency compressor.
- Door frame heater prevents condensation.
- Stainless steel interior standard.
- Optional vinyl-coated nesting shelves and bottom rack.
- Optional third shelf for three, four and five foot models adds 25% more glass storage capacity.

## MODEL NOS.

- FR24 Series
- FR36 Series
- FR48 Series
- FR60 Series

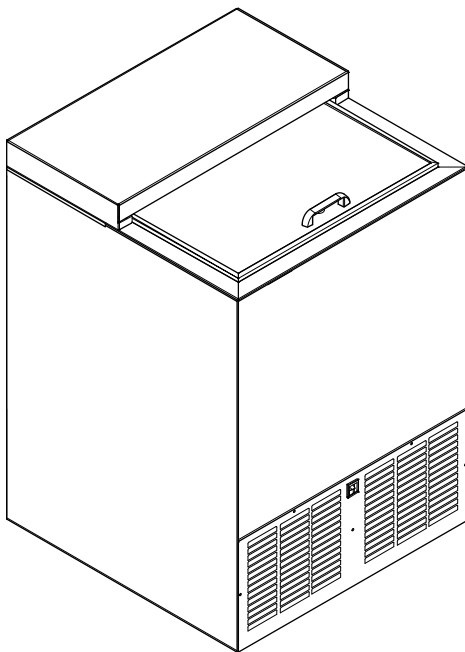

FR24 Series

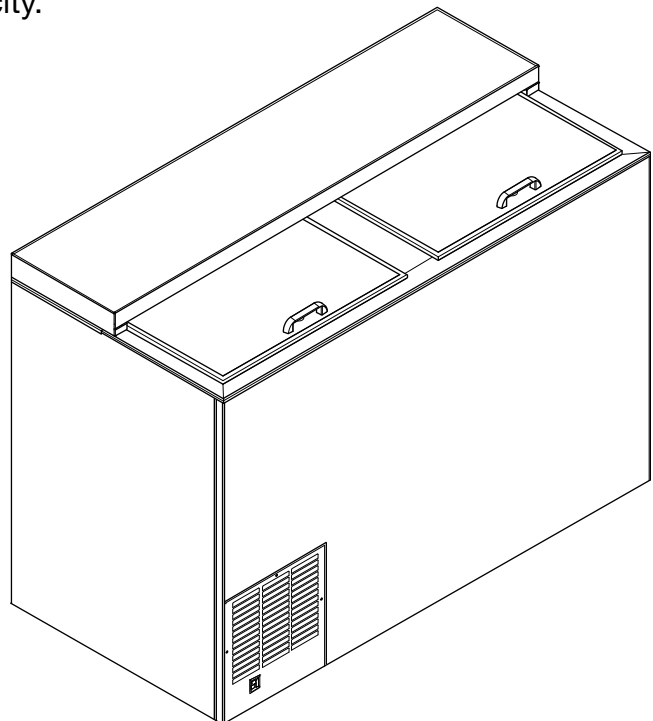

FR48 Series



8300 West Good Hope Road • Milwaukee, WI 53223 • Phone 414-353-7060 • Fax 414-353-7069  
Toll Free 800-558-5592 • E-Mail: [Perlick@Perlick.com](mailto:Perlick@Perlick.com) • [www.Perlick.com](http://www.Perlick.com)

# Sizes and Specifications Glass Frosters

Job \_\_\_\_\_  
 Area \_\_\_\_\_  
 Item No. \_\_\_\_\_  
 Model No. \_\_\_\_\_

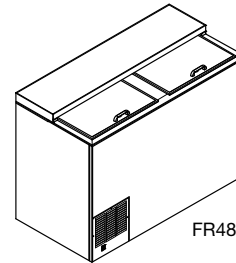
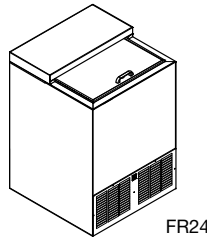

MODEL NOS.		FR24	FR36	FR48	FR60
CABINET DIMENSIONS	Length - Inches (mm)	24" (610)	36" (915)	48" (1219)	60" (1524)
	Depth - Inches (mm)	24" (610)	24" (610)	24" (610)	24" (610)
	Height - Inches (mm)	34 1/8" (867)	34" (864)	34" (864)	34" (864)
INTERIOR CUBIC FOOT (m <sup>3</sup> )		3.75 (0.10)	7.83 (0.22)	11.68 (0.33)	15.53 (0.44)
PLATE CAPACITY†		135 Plates	215 Plates	300 Plates	400 Plates
GLASS CAPACITY† - (w/2 Optional Shelves)		90 Glasses	142 glasses	214 glasses	286 glasses
GLASS CAPACITY† - (w/Optional Third Shelf)		N/A	172 glasses	273 glasses	363 glasses
CONDENSER UNIT H.P.		1/3	1/3	1/3	1/3
AMPS		5.8	6.8	6.2	7.1
SHIP WT Lbs. (kg)		190 (86)	245 (111)	265 (120)	300 (136)
INTERIOR	All models have stainless steel walls and floor.				
EXTERIOR	Choice of black, stainless steel and all stainless. <b>Black Option:</b> Front and ends are black vinyl coated steel, back and bottom are galvanized. <b>Stainless Steel Option:</b> Front and ends are stainless steel, back and bottom are galvanized. <b>All Stainless Option:</b> Front, ends, back and bottom are all stainless steel.				
DOORS (Sliding)	Stainless steel top and bottom pans. Die cast handle.				
ELECTRICAL	115V, 60 Hz., 1 Phase. Furnished with 6 foot rubber plug-in cord (115V model only). Also available in 230V, 50Hz., 1 Phase AC. carries CE marking of conformity.				
PLUMBING	None required. Moisture drains to self-evaporating condensing pan in machinery compartment.				
INSULATION	2 inch foamed-in-place polyurethane insulation.				
TEMPERATURE RANGE	Adjustable from -10° to +10° F.				
REFRIGERATION	R134a expansion valve system with hermetic condensing unit. Pulls out for service and cleaning.				
VENTILATION	2" model is front vented, all other models require 2" clearance from wall either on left end or back of cabinet for proper air flow.				
DEFROST SYSTEM	Solid-state, push-button defrost system, manually initiated at end of each day, automatically terminates after six hours. Evaporator automatically defrosts every 4 hours for approximately 20 minutes (time/temperature terminated).				
OPTIONAL ACCESSORIES & MODIFICATIONS	<ul style="list-style-type: none"> <li>• Additional set of nesting shelves w/ brackets</li> <li>• Interior light</li> <li>• Roller basket shelving</li> <li>• Set of 4 casters w/ brakes</li> <li>• Set of 4 adjustable legs</li> <li>• Thermometer (installed)</li> <li>• 2', 3', 4' and 5' Bottle rail (field installed)</li> </ul>				

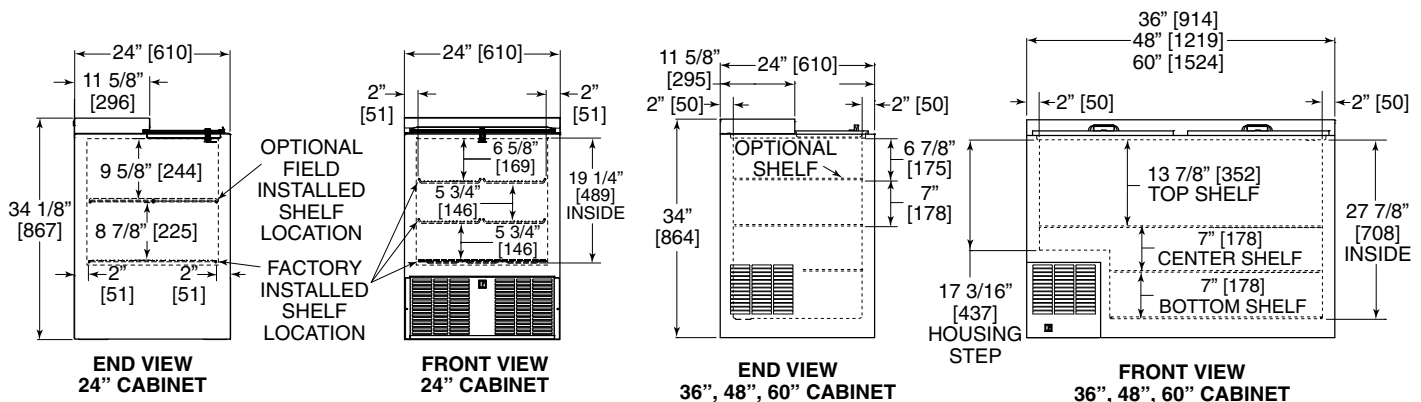

8300 West Good Hope Road • Milwaukee, WI 53223 • Phone 414-353-7060 • Fax 414-353-7069  
 Toll Free 800-558-5592 • E-Mail: Perlick@Perlick.com • www.Perlick.com

Perlick is committed to continuous improvement.  
 Therefore, we reserve the right to change specifications without prior notice.

Form No. 120303  
 Rev. 07.14.10