

CORNER FILLER SECTIONS INSIDE CORNERS WITH DRAINBOARD TOP

Perlick Features

- Embossed stainless steel drainboard.
- Underside reinforced.

MODEL NOS.

- TS Series
- 7055-152
 - 7055-160
 - 7055-162

MODEL NOS.

- TSD Series
- 7055D152

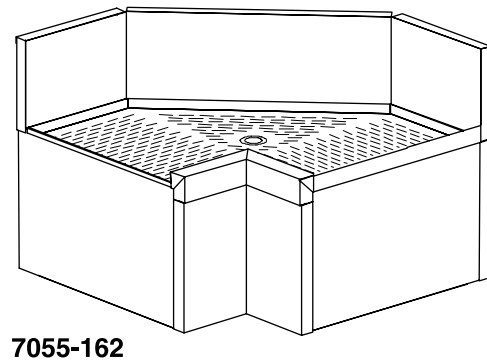
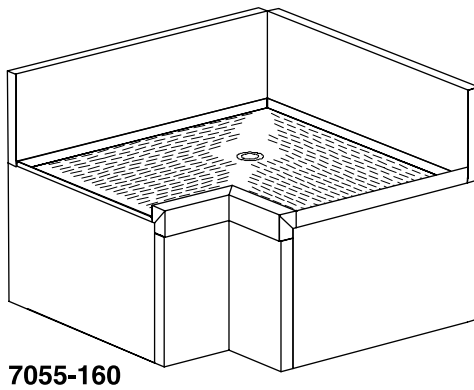
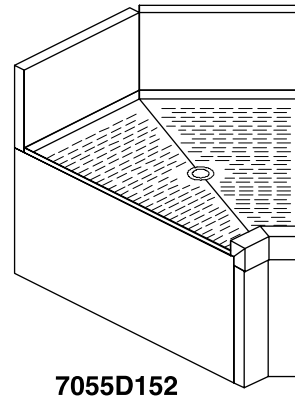
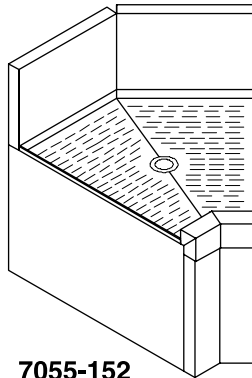

Sizes and Specifications - Corner Filler Sections Inside Corners with Drainboard Top

Job _____
 Area _____
 Item No. _____
 Model No. _____

MODEL NOS.	7055-152	7055D152	7055-160	7055-162
DESCRIPTION	45° Clip	45° Clip	90° Full	90° Clip
SHIP WT. lbs. (kg)	45 (20)	45 (20)	55 (25)	50 (23)
FRONT & SIDES	Stainless steel.			
BACK	Galvanized steel			
BACKSPLASH	General: Stainless steel 6" high (4" high optional) with 1" return at top, mechanically fastened and sealed with steel support brackets.			
DRAINBOARD	Embossed stainless steel. All horizontal and vertical edges 1/4" radius with balled corners. Underside reinforced with welded brackets. TS Series: 16" deep front to back. TSD Series: 21 7/16" front to back. Stainless steel drain socket.			
LEGS (Optional)	1 5/8" tubular, stainless steel with 1" adjustable thermoplastic foot.			
PLUMBING	Drain connection - 1 1/2" NPS Male.			

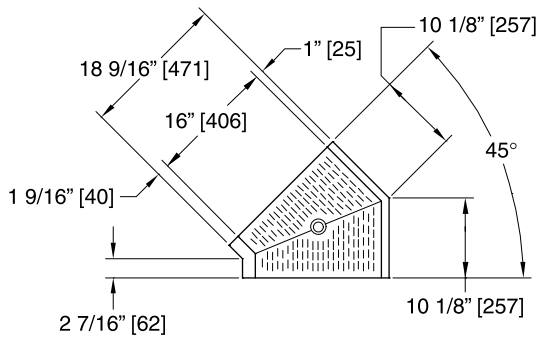

7055-152

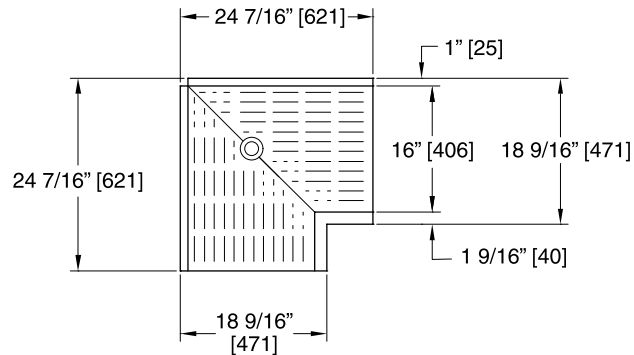

7055-160

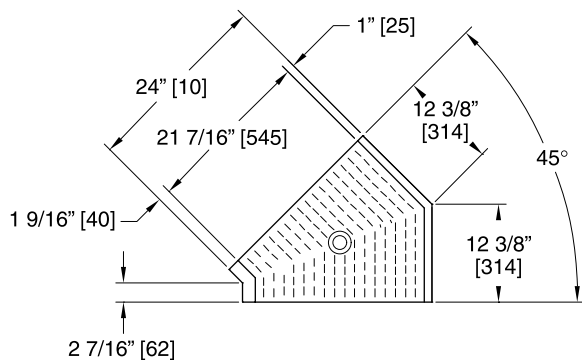

7055D152

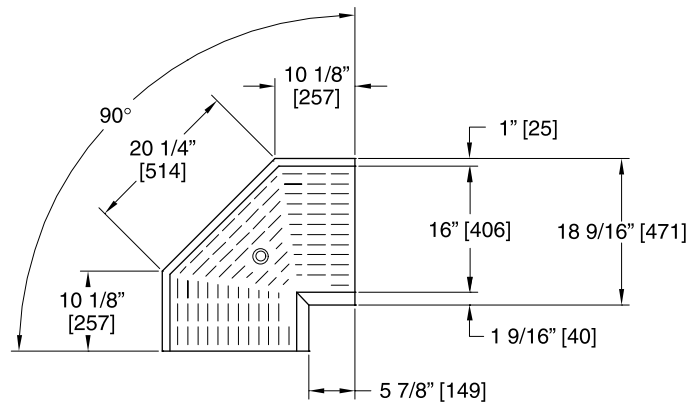

7055-162



8300 West Good Hope Road • Milwaukee, WI 53223 • Phone 414-353-7060 • Fax 414-353-7069
 Toll Free 800-558-5592 • E-Mail: Perlick@Perlick.com • www.Perlick.com

Perlick is committed to continuous improvement.
 Therefore, we reserve the right to change specifications without prior notice.

Form No. CF03
 Rev. 03.30.05