



DROP IN ICE CHESTS

Perlick Features

- Patented design conceals cold plate under liner for improved sanitation. (7600A24-8 & 7600A36-8)
- Drops into bar or countertop.

MODEL NOS.

- 7600A24
- 7600A24-8
- 7600A36
- 7600A36-8

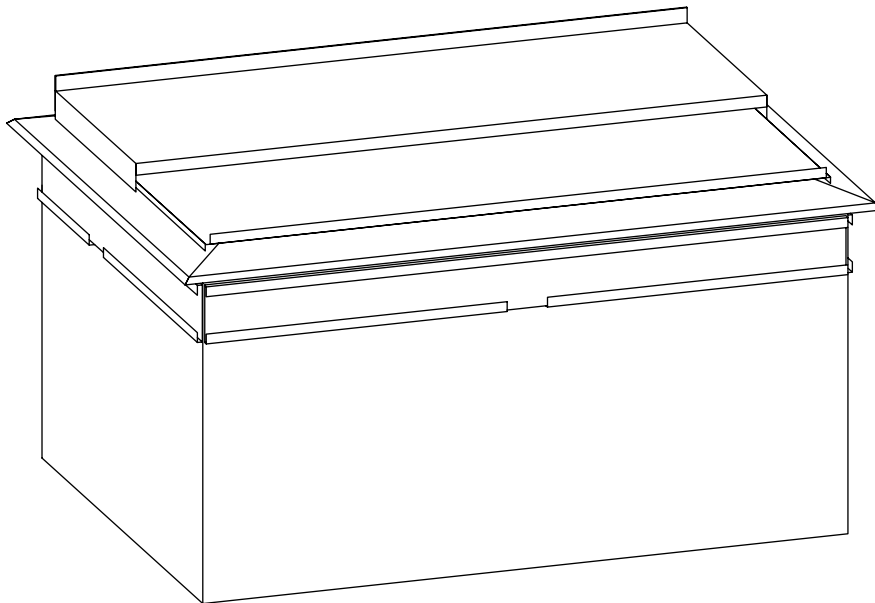

8300 West Good Hope Road • Milwaukee, WI 53223 • Phone 414-353-7060 • Fax 414-353-7069
Toll Free 800-558-5592 • E-Mail: Perlick@Perlick.com • www.Perlick.com



Sizes and Specifications Drop In Ice Chests

Job _____
 Area _____
 Item No. _____
 Model No. _____

MODEL NOS.	7600A24	7600A24-8	7600A36	7600A36-8
OUTSIDE LENGTH IN. (mm)	26" (660)	26" (660)	38" (970)	38" (970)
INSIDE LENGTH IN. (mm)	21 ³ / ₄ " (550)	21 ³ / ₄ " (550)	33 ³ / ₄ " (860)	33 ³ / ₄ " (860)
ICE CAP. lbs. (kg)	50 (23)	50 (23)	85 (39)	85 (39)
NO. OF CIRCUITS	0	8	0	8
HOLE SIZE	24 ¹ / ₂ " x 17 ³ / ₄ "	24 ¹ / ₂ " x 17 ³ / ₄ "	36 ¹ / ₂ " x 17 ³ / ₄ "	36 ¹ / ₂ " x 17 ³ / ₄ "
SHIP WT lbs. (kg)	60 (27)	160 (73)	110 (50)	210 (95)
TOP	Stainless steel.			
FRONT & SIDES	Galvanized steel.			
BOTTOM	Galvanized steel.			
COVERS	Stainless steel, two-piece, removable.			
INTERIOR	Stainless steel with 1/4" radius corners, sealed with non-exposed cold plate.			
INSULATION	Foamed-in-place polyurethane.			
PLUMBING	Drain Connection - 1/2" NPS Male.			
COLD PLATE	Cast aluminum plate concealed under ice chest liner. Cold plate has 2 full-length circuits and 6 half-length circuits. Connections — 5/16" O.D. stainless steel tubing with swaged end to accept standard 1/4" I.D. beverage tubing.			
OPERATING SPECIFICATIONS	Each full circuit will deliver four, 6 oz. drinks per minute at 40° continuously, or 40 oz. every three minutes in a single draw (Flow rate 2 oz./sec., 75° ambient, 75° product).			

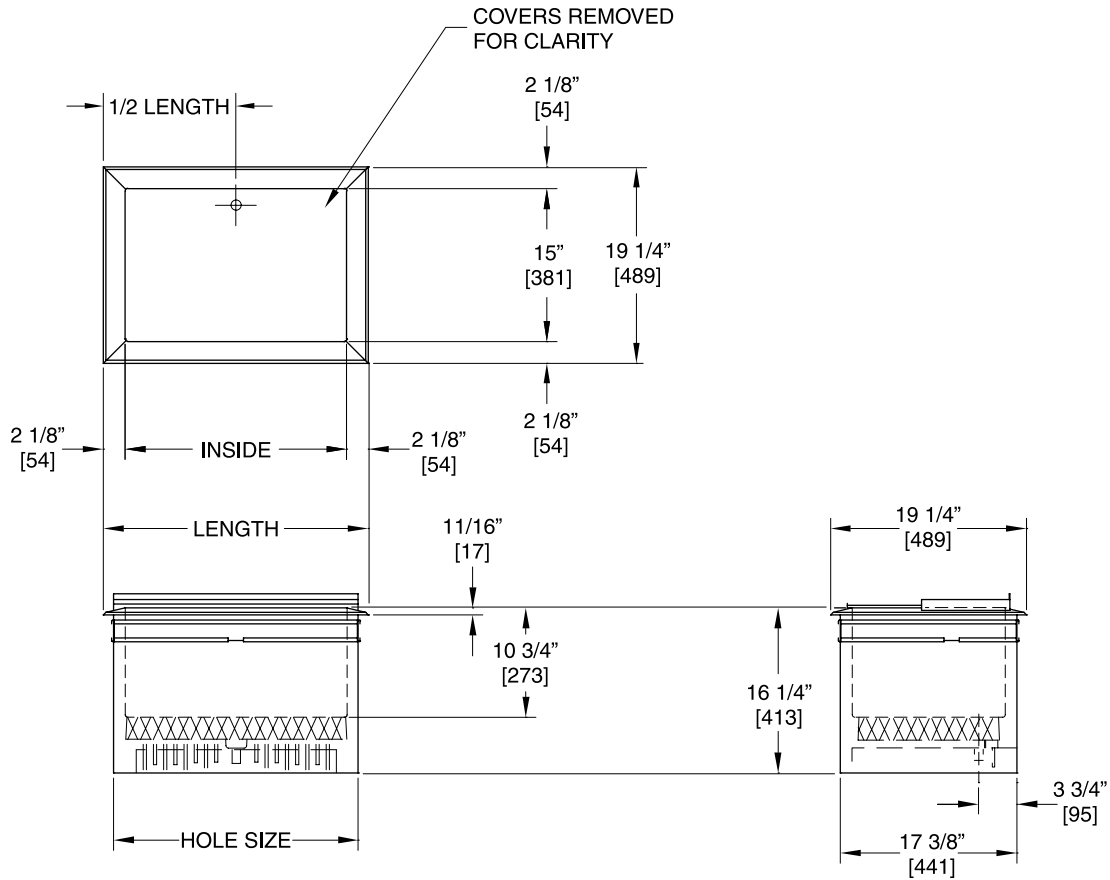

8300 West Good Hope Road • Milwaukee, WI 53223 • Phone 414-353-7060 • Fax 414-353-7069
 Toll Free 800-558-5592 • E-Mail: Perlick@Perlick.com • www.Perlick.com

Perlick is committed to continuous improvement.
 Therefore, we reserve the right to change specifications without prior notice.

Form No. IC04
 Rev. 03.30.05