

ICE CREAM CENTER

Perlick Features

- Refrigerated ice cream unit.
- Convenient disher well and faucet.
- Stainless steel legs install without tools and have "Rust Free" Thermoplastic feet.

MODEL NOS.

TS Series
 TS24DC

MODEL NOS.

TSD Series
 TSD24DC

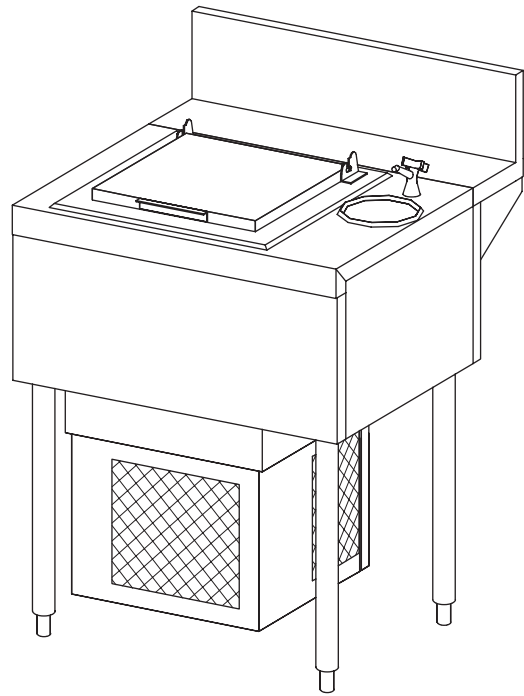
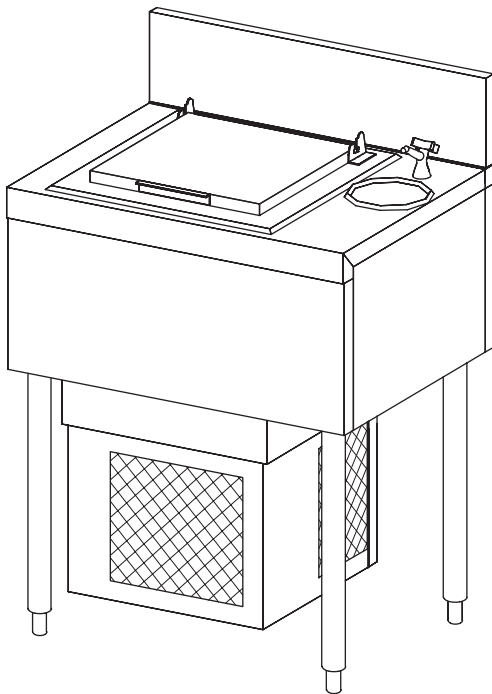

8300 West Good Hope Road • Milwaukee, WI 53223 • Phone 414-353-7060 • Fax 414-353-7069
Toll Free 800-558-5592 • E-Mail: Perlick@Perlick.com • www.Perlick.com

Form No. DC01
Rev. 07.03.07

Sizes and Specifications Ice Cream Center

Job _____
 Area _____
 Item No. _____
 Model No. _____

MODEL NOS.	TS(D)24DC
LENGTH INS. (mm)	24" (610)
SHIP WT lbs. (kg)	199 (90)
TOP, FRONT & SIDES	Stainless steel.
BACK & BOTTOM	Galvanized steel.
BACKSPLASH	TS Series: Stainless steel 6" high (4" high optional) with 1" return at top, mechanically fastened and sealed with steel support brackets. TSD Series: Stainless steel rear deck.
LEGS	1 ⁵ / ₈ " tubular, stainless steel with 1" adjustable thermoplastic foot.
DISH WELL & FAUCET	5" stainless steel disher well with removable perforated basket. Chrome-plated fine-stream faucet.
DROP-IN ICE CREAM UNIT	Stainless steel top and removable hinged door lid. Ice cream well: No. 2B dull stainless steel. NSF listed.
ELECTRICAL	115 volt, 60 hz, 1 phase AC. Furnished with six foot rubber cord. Running load: 4 amps. Also available in 230 volt, 50 hz., 1 phase CE marked.
REFRIGERATION	1/5 h.p.
PLUMBING	Drain-connection - 1" NPS Male. Cold water connection: 1/2" IPS shank (includes 1/4" MPT tailpiece).

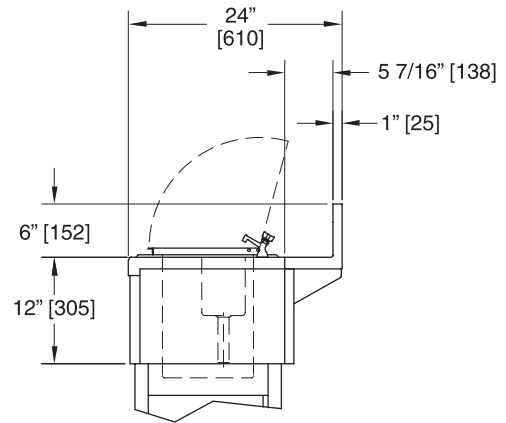
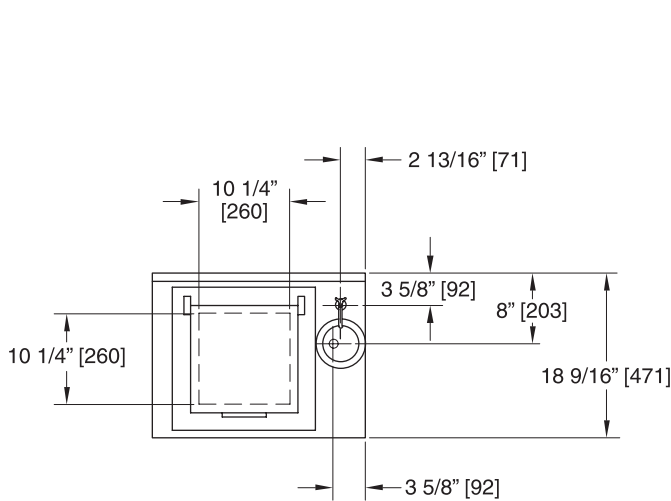

TSD END VIEW

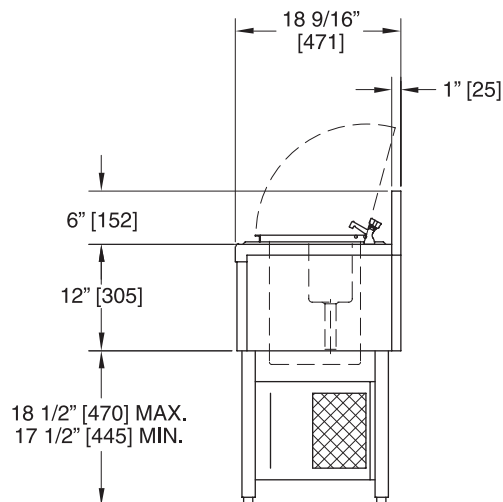
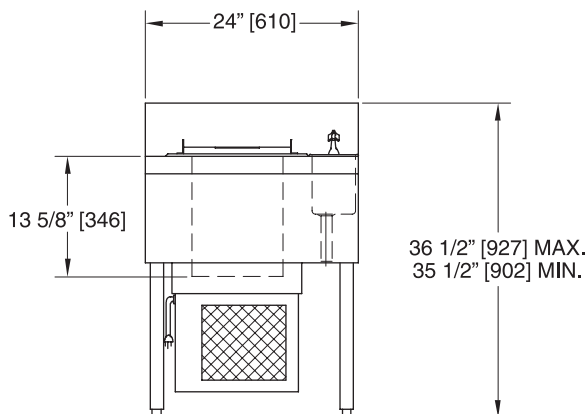

TS END VIEW



8300 West Good Hope Road • Milwaukee, WI 53223 • Phone 414-353-7060 • Fax 414-353-7069
 Toll Free 800-558-5592 • E-Mail: Perlick@Perlick.com • www.Perlick.com

Perlick is committed to continuous improvement.
 Therefore, we reserve the right to change specifications without prior notice.

Form No. DC01
 Rev. 07.03.07