

Combination Refrigerated Service Above Refrigerated Self-Service Case



MODEL SHOWN: HURLR4852
 WITH OPTIONAL DISPLAY STEPS IN LOWER AREA.

- HURLR3852 40"L x 42"D x 53"H
- HURLR4852 50"L x 42"D x 53"H
- HURLR5652 58"L x 42"D x 53"H
- HURLR7452 76"L x 42"D x 53"H

STANDARD FEATURES

- Light-T-8 top & shelf lights
- Evaporator pan-Electric condensate pan (self-contained refig. only)
- Compressor air-Compressor air rear intake, front discharge. Toe kick cannot be blocked
- Warranty-One year parts & labor; 1-5 year compressor warranty
- Upper display-Refrigerated upper display
- Temp-Integrated average product temperature of 41°F or less.
- Ends-Full end panel w/mirror interior
- Shelves-Shelving removable and adjustable on 1" centers

	STANDARD SPECIFICATION	OPTION(S)
ELECTRICAL CONNECT	<input type="checkbox"/> 6 ft straight blade power cord (self cont.)	<input type="checkbox"/> 6 ft locking power cord (self cont.) <input type="checkbox"/> Electrical leads (remote)
LOWER DISPLAY	<input type="checkbox"/> Single deck display	<input type="checkbox"/> 2"H Display steps (n/a w/shelf) <input type="checkbox"/> 4"H Display steps (n/a w/shelf) <input type="checkbox"/> Clear glass shelf, lighted <input type="checkbox"/> 2"H Full depth display riser(s) (n/a w/shelf) <input type="checkbox"/> 4"H Full depth display risers (n/a w/shelf) <input type="checkbox"/> Smoked glass shelf, lighted
UPPER DISPLAY	<input type="checkbox"/> Clear glass shelf, lighted	<input type="checkbox"/> Smoked glass shelf, lighted
INTERIOR COLOR	<input type="checkbox"/> Black interior	<input type="checkbox"/> White interior <input type="checkbox"/> Stainless Steel interior
TRIM COLOR	<input type="checkbox"/> Black trim	<input type="checkbox"/> Silver trim <input type="checkbox"/> Gold trim
EXTERIOR COLOR	<input type="checkbox"/> Laminated exterior (Wilsonart/Formica non-premium)	<input type="checkbox"/> Maple veneer exterior (stained) <input type="checkbox"/> Painted exterior (specify color) <input type="checkbox"/> Laminated exterior (Wilsonart/Formica premium) <input type="checkbox"/> Oak veneer exterior (stained) <input type="checkbox"/> Stainless steel exterior
COVER/CURTAIN	<input type="checkbox"/> None	<input type="checkbox"/> Removable wire security cover, locking <input type="checkbox"/> Night curtain, retractable, non-locking
REFRIGERATION	<input type="checkbox"/> Breeze™ refrigeration	<input type="checkbox"/> Note: Remote does Not include Condensing unit <input type="checkbox"/> Remote w/thermostat, solenoid & TXV <input type="checkbox"/> Remote w/TXV
BASE SUPPORT	<input type="checkbox"/> Levelers	<input type="checkbox"/> Casters
FRONT PANEL	<input type="checkbox"/> Straight front panel	<input type="checkbox"/> ABS upper front panel
REAR DOORS	<input type="checkbox"/> Clear glass rear sliding doors w/o lock	<input type="checkbox"/> Reflective glass rear sliding doors w/lock <input type="checkbox"/> Clear glass rear sliding doors w/lock <input type="checkbox"/> Reflective glass rear sliding doors w/o lock
REAR WRAPPING BOARD	<input type="checkbox"/> None	<input type="checkbox"/> Rear wrapping board
ACRYLIC TOP DISPLAY	<input type="checkbox"/> None	<input type="checkbox"/> Acrylic display w/sliding doors
FRONT GLASS	<input type="checkbox"/> Curved double pane, lift-up front glass w/o lock	<input type="checkbox"/> Non-glare, curved double pane, lift-up front glass w/o lock <input type="checkbox"/> Non-glare, curved double pane, lift-up front glass w/lock <input type="checkbox"/> Curved double pane, lift-up front glass w/lock
BUMPER	<input type="checkbox"/> None	<input type="checkbox"/> 1" bumper on front (specify color)

ENCORE®

PRODUCT SPECIFICATIONS

Intended Use of Display Area: Packaged/unpackaged refrigerated products
 Integrated Product Temperature (IPT): 41°F
 Intended Environment: Designed to operate in ambient conditions of 75°F / 55% relative humidity.

PLAN VIEW

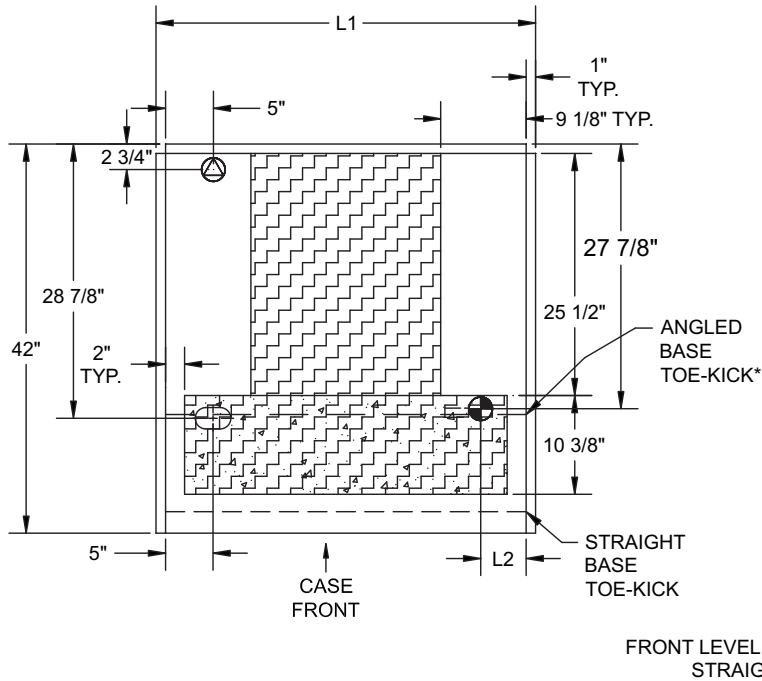

SIDE VIEW

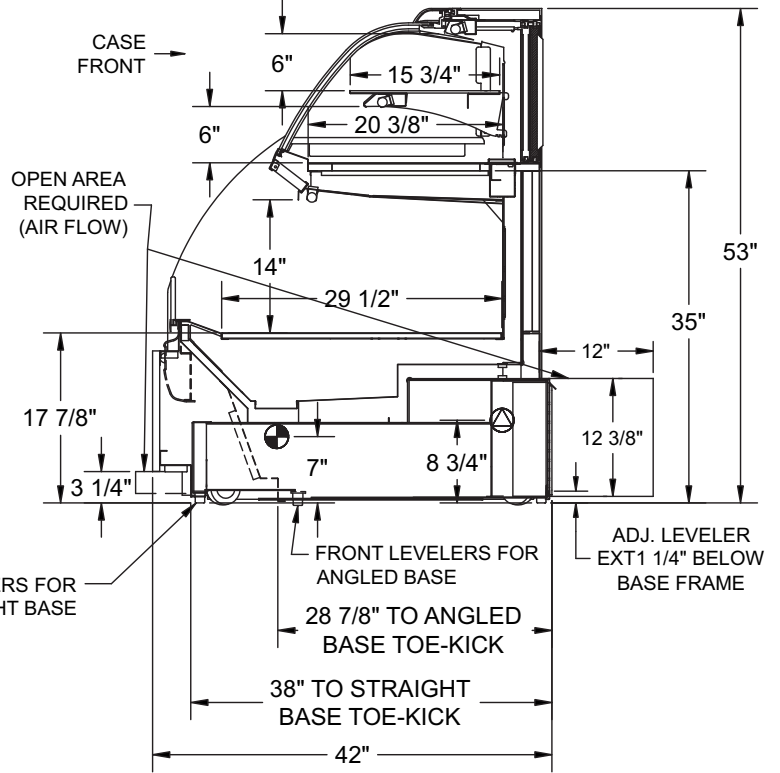

*FOR ANGLD BASE CASES, SERVICE ACCESS AREAS END AT TOE-KICK

NOTE: ALL DIMENSIONS APPROXIMATE

- ELECTRICAL JUNCTION BOX (SUPPLIED WITH 6" LEADS OR POWER CORD).
- LOCATION OF CONDENSATE DRAIN TUBE (SUPPLIED WITH 3/4" OR 1 1/2" PVC DRAIN TUBE).
- REFRIGERATION LINE CONNECTION.
- REMOTE CASE SERVICE ACCESS AREA.
- SELF-CONTAINED CASE SERVICE ACCESS AREA.
- DRY CASE SERVICE ACCESS AREA.

Model	Self-Contained Refrigeration/Dry					Remote Refrigeration w/Leads			Ship Wt	Frt CIs
	L1*	L2*	Volts++	Amps	NEMA Plug	Volts++	Amps***	BTUH		
HURLR3852	40	10 3/8	120/1/60	17.18	NEMA 5-20P	120/1/60	2.72	2948	850	110
HURLR4852	50	10 3/8	220/1/60**	13.41	NEMA 14-20P	120/1/60	2.96	3431	890	110
HURLR5652	58	10 3/8	220/1/60**	13.51	NEMA 14-20P	120/1/60	3.06	3817	900	110
HURLR7452	76	10 3/8	220/1/60**	19	NEMA 14-30P	120/1/60	4.4	4686	1200	110

++ Operating range for 120 volt rating is 110-120 volts; operating range for 220 volt rating is 208-230 volts.

** Requires 3 wires + ground

*** Does not include electric defrost on freezer models

REGULATORY APPROVALS

- ETL Listed Certified to CAN/CSA 22.2
- ETL Listed Conforms to UL 471
- ETL Sanitation Conforms to NSF 7

Important Note:

43" Minimum door entry clearance required (without shipping skid).

Important Note:

Compressor air intake from rear and out front panel at toe kick. Toe kick cannot be blocked.

Important Note:

Units are supplied with levelers. They must be adjusted during installation to ensure the unit is level and plumb. Dimensions reflect levelers extended 1 1/4".



Note: Information is subject to change at any time.

888 E. Porter Rd. Muskegon, MI 49441 Phone: 231.798.8888 Fax: 231.798.4960 www.structuralconcepts.com