

Refrigerated Service Single Deck Inside Corner Case - Spherical Front Glass

RTSIW45 56 5/8"L x 44 1/2"D x 54"H
 RTSIW90 102 3/8"L x 44 1/2"D x 54"H

STANDARD FEATURES

- Electrical connect-Electrical leads (remote)
- Temp-Integrated average product temperature of 41°F
- Warranty-One year parts & labor warranty
- Lower rear-Non-refrigerated rear storage (w/o doors)
- Upper front-Spherical, single pane, fixed front glass



MODEL SHOWN: RTSIW45

NOTE: SHOWN W/ OPTIONAL END PANELS

	STANDARD SPECIFICATION	OPTION(s)
DISPLAY SURFACE	<input type="checkbox"/> Solid Surface Corian - Night Sky	<input type="checkbox"/> Solid surface, special colors (call for quote)
FRONT LEDGE	<input type="checkbox"/> Solid Surface Corian - Night Sky	<input type="checkbox"/> Solid surface, special colors (call for quote)
REAR EXTERIOR COLOR	<input type="checkbox"/> White exterior	<input type="checkbox"/> Stainless steel rear exterior (w/stainless ext. only) <input type="checkbox"/> Black exterior
INTERIOR COLOR	<input type="checkbox"/> Black interior	<input type="checkbox"/> White interior <input type="checkbox"/> Stainless Steel interior
TRIM COLOR	<input type="checkbox"/> Black trim	<input type="checkbox"/> Silver trim
EXTERIOR COLOR	<input type="checkbox"/> Laminated exterior (Wilsonart/Formica non-premium)	<input type="checkbox"/> Stainless steel exterior <input type="checkbox"/> Laminated exterior (Wilsonart/Formica premium)
REFRIGERATION	<input type="checkbox"/> Remote w/TXV	<input type="checkbox"/> Note: Remote doesn't incl Conds unit. Floor drain reqd. <input type="checkbox"/> Remote w/thermostat, solenoid & TXV
BASE SUPPORT	<input type="checkbox"/> Levelers	<input type="checkbox"/> 6"H legs
FRONT PANEL	<input type="checkbox"/> Flat front panel	<input type="checkbox"/> Step front (Increases depth of unit 10")
TOE KICK	<input type="checkbox"/> Toe kick, black	<input type="checkbox"/> Toe kick, white <input type="checkbox"/> Toe kick, stainless steel
END PANEL LEFT	<input type="checkbox"/> No end panel (for same case to case connections)	<input type="checkbox"/> Full end panel <input type="checkbox"/> Case to case glass end
END PANEL RIGHT	<input type="checkbox"/> No end panel (for same case to case connections)	<input type="checkbox"/> Full end panel <input type="checkbox"/> Case to case glass end
BACK PANEL	<input type="checkbox"/> Solid back panel, white	<input type="checkbox"/> Solid back panel, black <input type="checkbox"/> Solid back panel, stainless steel
REAR WORK LEDGE	<input type="checkbox"/> Solid Surface Corian - Night Sky	<input type="checkbox"/> Solid surface, special colors (call for quote)
SHELVING	<input type="checkbox"/> None	<input type="checkbox"/> Smoked glass shelf, lighted (LED)
BUMPER	<input type="checkbox"/> None	<input type="checkbox"/> 1" bumper on front (specify color)

ENCORE®

PRODUCT SPECIFICATIONS

Intended Use of Display Area: Packaged/unpackaged refrigerated products
 Integrated Product Temperature (IPT): 41°F
 Intended Environment: Designed to operate in ambient conditions of 75°F / 55% relative humidity.

PLAN VIEW

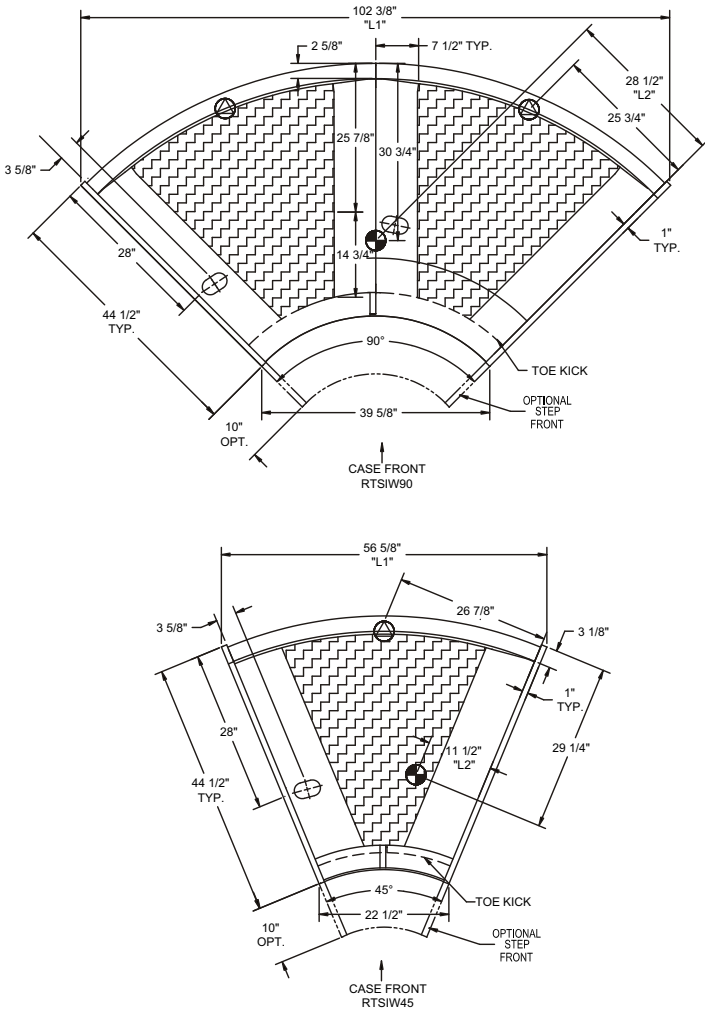

SIDE VIEW

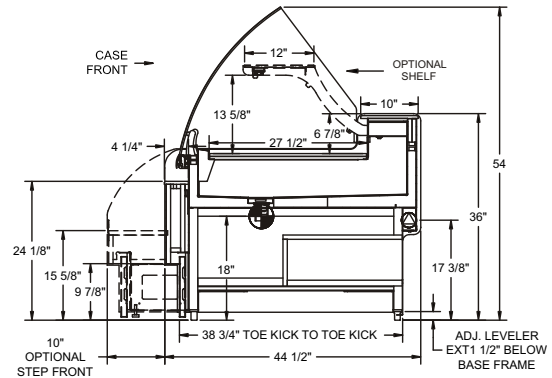

NOTE: ALL DIMENSIONS APPROXIMATE

- ELECTRICAL JUNCTION BOX (SUPPLIED WITH 6" LEADS OR POWER CORD).
- LOCATION OF CONDENSATE DRAIN TUBE (SUPPLIED WITH 3/4" OR 1 1/2" PVC DRAIN TUBE).
- REFRIGERATION LINE CONNECTION.
- REMOTE CASE SERVICE ACCESS AREA.
- SELF-CONTAINED CASE SERVICE ACCESS AREA.
- DRY CASE SERVICE ACCESS AREA.

Model	Self-Contained Refrigeration/Dry					Remote Refrigeration w/Leads			Ship Wt	Frt Cls
	L1*	L2*	Volts++	Amps	NEMA Plug	Volts++	Amps***	BTUH		
RTSIW45	56 5/8	11 1/2	N/A	0	N/A	120/1/60	1.23	1760	1200	110
RTSIW90	102 3/8	28 1/2	N/A	0	N/A	120/1/60	1.9	3520	1200	110

++ Operating range for 120 volt rating is 110-120 volts; operating range for 220 volt rating is 208-230 volts.

** Requires 3 wires + ground

*** Does not include electric defrost on freezer models

REGULATORY APPROVALS

- ETL Listed Conforms to UL 471 in process
- ETL Sanitation Conforms to NSF 7 in process

Important Note:

43" minimum door entry clearance required (without shipping skid).

Important Note:

Compressor air ventilation is out the front panel. Front panel cannot be blocked.

Important Note:

Units are supplied with levelers. They must be adjusted during installation to ensure the unit is level and plumb. Dimensions reflect levelers extended 1 1/2".