



KLS-DS

Direct Steam Tri-Leg Stationary Kettle



Project _____

Item No. _____

Quantity _____

- Model KLS-20DS - 20 gallon (76 litres) direct steam tri-leg stationary kettle
- Model KLS-30DS - 30 gallon (114 litres) direct steam tri-leg stationary kettle
- Model KLS-40DS - 40 gallon (151 litres) direct steam tri-leg stationary kettle
- Model KLS-60DS - 60 gallon (227 litres) direct steam tri-leg stationary kettle
- Model KLS-80DS - 80 gallon (303 litres) direct steam tri-leg stationary kettle
- Model KLS-100DS - 100 gallon (379 litres) direct steam tri-leg stationary kettle

CONSTRUCTION

- Water resistant construction
- 304 stainless steel construction
- 316 stainless steel interior cooking surface for added corrosion resistance for 20, 30 and 40 gallon
- 2/3 jacketed
- Hemispherical design on bottom of kettle for superior heat circulation
- Tubular stainless steel legs with flanged feet

STANDARD FEATURES

- 2" (50mm) draw off valve
- Hinged stainless steel counter balanced cover for 20, 30 & 40 gallon
- Spring assist hinged stainless steel cover for 60, 80 and 100 gallon
- Stainless steel faucet bracket
- One year parts and labor warranty*

* For all international markets, contact your local distributor.

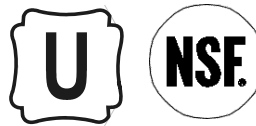

KLS-DS TRI-LEG STATIONARY KETTLE

OPTIONS AND ACCESSORIES

(AT ADDITIONAL CHARGE)

- **Etched markings**
 - Gallons
 - Litres
- **Draw Off valves and accessories**
 - 3" (76mm) draw off valve
 - 2" (50mm) dairy valve
 - 3" (76mm) dairy valve
 - Perforated strainer for draw off
 - Solid stainless steel disc for draw off valve
- **Covers**
 - Two piece stainless steel hinged cover for 60, 80 & 100 gallon
 - Spring assist hinged stainless steel cover for 20, 30 and 40 gallon
- **Faucets**
 - Single pantry faucet with swing spout
 - Double pantry faucet with swing spout
- 316 stainless steel liner for 60, 80 and 100 gallon
- 50 PSI (345 kPa) high pressure operation for higher cooking temperature
- Tri-basket assembly
- Strainer hook
- Graduated measuring strip
- Steam trap assembly consisting of steam trap, check valve, steam control valve, and line strainer
- Correctional package

BLODGETT

www.blodgett.com

44 Lakeside Avenue, Burlington, VT 05401 • Phone: (802) 658-6600 • Fax: (802) 864-0183



KLS-DS TRI-LEG STATIONARY KETTLE



APPROVAL/STAMP

DIMENSIONS ARE IN INCHES [MM].

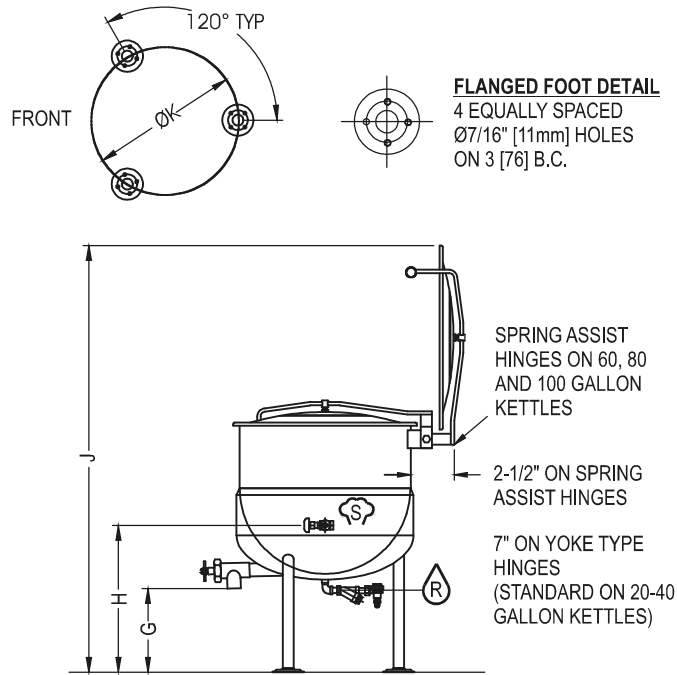
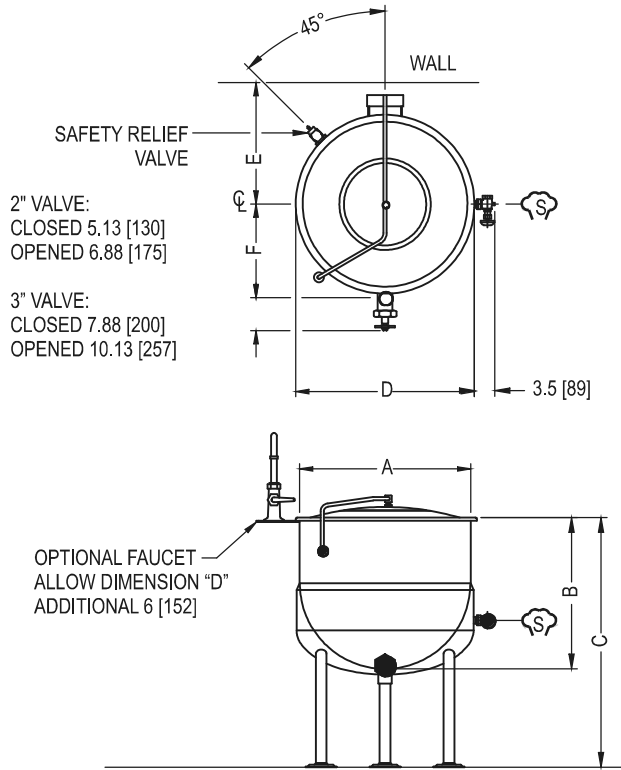

MODEL	A	B	C	D	E	F (2")	F (3")	G (2")	G (3")	H	J	K
KLS-20DS	21[533]	18[457]	37[940]	22.75[578]	16[406]	12.75[324]	14[356]	17[432]	16.5[419]	25.88[657]	59.75[1518]	17.5[445]
KLS-30DS	24[610]	20[508]	37[940]	25.88[657]	17.5[445]	13.5[343]	15.25[387]	15[381]	14.5[368]	26.88[683]	62.88[1597]	20.5[521]
KLS-40DS	26[660]	22.5[572]	37[940]	27.88[708]	18.5[470]	14.25[362]	16.5[419]	12.5[318]	12[305]	23.88[606]	64.88[1648]	22.5[572]
KLS-60DS	29.5[749]	26[660]	40.5[1029]	31.38[797]	17.75[451]	15.5[394]	17.25[438]	12.5[318]	12[305]	24.69[627]	72.88[1851]	25.75[654]
KLS-80DS	33[838]	28[711]	42.5[1080]	34.75[883]	19.5[495]	17.5[445]	19.25[489]	10.5[267]	10[254]	23.88[606]	75.25[1911]	29.25[743]
KLS-100DS	35.5[902]	30[762]	44.5[1130]	37.25[946]	20.75[527]	17[432]	19.25[489]	12.5[318]	12[305]	26.63[676]	81.75[2076]	31.75[806]

SHORT FORM SPECIFICATIONS

Provide Blodgett model KLS-20DS (20 gallon), KLS-30DS (30 gallon), KLS-40DS (40 gallon), KLS-60DS (60 gallon), KLS-80DS (80 gallon) or KLS-100DS (100 gallon) direct steam tri-leg stationary kettle. The unit shall have a double wall interior to form a steam jacket around the lower 2/3 of the kettle. The bottom of the kettle shall be of hemispherical design for superior heat circulation. Unit shall be mounted on stainless steel tubular tri-legs. Each leg shall be fitted with a four hole adjustable flanged foot for securing to the floor. Construction shall be all welded satin finish 304 stainless steel. 20, 30 and 40 gallon models shall have a 316 stainless steel liner. Unit shall have a 2" draw off valve. 20, 30 and 40 gallon units shall have hinged, counterbalanced stainless steel domed cover. 60, 80 and 100 gallon units shall have a spring assist hinged stainless steel domed cover. The unit shall be ASME code stamped and National Board registered. Provide options and accessories as indicated.

PIPING REQUIREMENTS:

Steam Supply 3/4" IPS
 Condensate Return 1/2" IPS

STEAM PRESSURE:

Minimum 5 PSI (34 kPa)
 Maximum 35 PSI (241 kPa) standard kettle
 50 PSI (345 kPa) optional high pressure kettle

Pressure reducing valve required if incoming steam pressure exceeds the kettle rating.

WATER SUPPLY:

Cold Water 3/8" nominal tubing to optional pantry faucet

SHIPPING INFORMATION:

Approx. Weight:

KLS-20DS 205 lbs. (93 kg)
 KLS-30DS 230 lbs. (104 kg)
 KLS-40DS 240 lbs. (109 kg)
 KLS-60DS 315 lbs. (143 kg)
 KLS-80DS 355 lbs. (161 kg)
 KLS-100DS 410 lbs. (186 kg)

NOTE: The company reserves the right to make substitutions of components without prior notice.

BLODGETT

www.blodgett.com

44 Lakeside Avenue, Burlington, VT 05401 • Phone: (802) 658-6600 • Fax: (802) 864-0183